**Ambient air — Determination of asbestos
fibres — Indirect-transfer transmission
electron microscopy method**

*Air ambiant — Dosage des fibres d'amiante — Méthode par microscopie
électronique à transmission par transfert indirect*



Contents

	Page
1 Scope	1
1.1 Substance determined	1
1.2 Type of sample	1
1.3 Range	1
1.4 Limit of detection	1
2 Terms and definitions	2
3 Abbreviated terms	6
4 Principle	6
5 Apparatus	7
5.1 Air sampling	7
5.2 Specimen preparation laboratory	8
5.3 Equipment for analysis	8
5.4 Consumable supplies	13
6 Reagents	14
7 Air sample collection	14
7.1 Calculation of analytical sensitivity	14
7.2 Sample collection procedure	15
8 Procedure for analysis	15
8.1 General	15
8.2 Cleaning of sample cassettes	16
8.3 Preparation of analytical filters	16
8.4 Preparation of TEM specimens from PC analytical filters	17

© ISO 1999

All rights reserved. Unless otherwise specified, no part of this publication may be reproduced or utilized in any form or by any means, electronic or mechanical, including photocopying and microfilm, without permission in writing from the publisher.

International Organization for Standardization
Case postale 56 • CH-1211 Genève 20 • Switzerland
Internet iso@iso.ch

Printed in Switzerland

Licensed to IATL/JOHN NAPOLITAN
ISO Store order #:852310/Downloaded:2007-10-04
Single user licence only, copying and networking prohibited

8.5 Preparation of TEM specimens from cellulose ester analytical filters	19
8.6 Criteria for acceptable TEM specimen grids	20
8.7 Procedure for structure counting by TEM	21
8.8 Blank and quality control determinations	24
8.9 Calculation of results	25
9 Performance characteristics	25
9.1 General	25
9.2 Interferences and limitations of fibre identification	25
9.3 Precision and accuracy	26
9.4 Limit of detection	26
10 Test report	27
Annex A (normative) Determination of operating conditions for plasma asher	30
Annex B (normative) Determination and standardization of operating conditions for ultrasonic bath	31
Annex C (normative) Calibration procedures	33
Annex D (normative) Structure-counting criteria	36
Annex E (normative) Fibre identification procedure	44
Annex F (normative) Determination of concentrations of asbestos fibres and bundles longer than 5 µm, and of PCM-equivalent asbestos fibres	53
Annex G (normative) Calculation of results	54
Annex H (normative) Test procedure to determine suitability of cellulose ester sample collection filters	60
Annex I (informative) Strategies for collection of air samples	61
Bibliography	62

Foreword

ISO (the International Organization for Standardization) is a worldwide federation of national standards bodies (ISO member bodies). The work of preparing International Standards is normally carried out through ISO technical committees. Each member body interested in a subject for which a technical committee has been established has the right to be represented on that committee. International organizations, governmental and non-governmental, in liaison with ISO, also take part in the work. ISO collaborates closely with the International Electrotechnical Commission (IEC) on all matters of electrotechnical standardization.

International Standards are drafted in accordance with the rules given in the ISO/IEC Directives, Part 3.

Draft International Standards adopted by the technical committees are circulated to the member bodies for voting. Publication as an International Standard requires approval by at least 75 % of the member bodies casting a vote.

International Standard ISO 13794 was prepared by Technical Committee ISO/TC 146, *Air quality*, Subcommittee SC 3, *Ambient atmospheres*.

Annexes A to H form a normative part of this International Standard. Annex I is for information only.

Introduction

This International Standard is applicable to the measurement of airborne asbestos in a wide range of ambient air situations, including the interior atmospheres of buildings, and for detailed evaluation of any atmosphere in which asbestos fibres are likely to be present. Because the best available medical evidence indicates that the numerical fibre concentration and the fibre size and type are the relevant parameters for evaluation of the inhalation hazards, a fibre counting and measuring technique is the only logical approach. Most fibres in ambient atmospheres are not asbestos, and therefore there is a requirement for fibres to be identified. Many airborne asbestos fibres in ambient atmospheres have diameters below the resolution limit of the optical microscope. This International Standard is based on transmission electron microscopy, which has adequate resolution to allow detection of small fibres and is currently the only technique capable of unequivocal identification of the majority of individual fibres of asbestos. The fibres found suspended in an ambient atmosphere can often be identified unequivocally, if sufficient measurement effort is expended. However, if each fibre were to be identified in this way, the analysis becomes prohibitively expensive. Because of instrumental deficiencies or because of the nature of the particulate, some fibres cannot be positively identified as asbestos, even though the measurements all indicate that they could be asbestos. Subjective and instrumental factors therefore contribute to this measurement, and consequently a very precise definition of the procedure for identification and enumeration of asbestos fibres is required.

In addition to single fibres and bundles, asbestos is often found in air samples as very complex, aggregated structures which may or may not be also aggregated with other particles. The number of asbestos fibres and bundles incorporated in these complex structures often exceeds the number of isolated fibres and bundles observed, and many of them may be completely obscured in direct-transfer TEM preparations. The method defined in this International Standard incorporates specimen preparation procedures that result in selective concentration of asbestos fibres, and removal of organic and water-soluble materials. These procedures have the effect of dispersing the majority of the complex clusters and aggregates of fibres into their component fibres and bundles so that the asbestos in the air sample can be more accurately quantified. All of the feasible specimen preparation techniques result in some modification of the airborne particulate. Even the collection of particles from a three-dimensional airborne dispersion on to a two-dimensional filter surface can be considered a modification of the particulate, and some of the particles in most samples are modified by the specimen preparation procedures. Although this method results in dispersal of complex clusters and aggregates, it minimizes other effects on the size distribution of fibres and fibre bundles.

This International Standard is necessarily complex, because the instrumental techniques used are complex, and also because a very detailed and logical procedure must be specified to reduce the subjective aspects of the measurement. The method of data recording specified in this International Standard is designed to allow re-evaluation of the fibre counting data as new medical evidence becomes available.

This International Standard describes the method of analysis for a single air filter. However, one of the largest potential errors in characterizing asbestos in ambient atmospheres is associated with the variability between filter samples. For this reason, it is necessary to design a replicate sampling scheme in order to determine the standard's accuracy and precision.

Comparison of results obtained using this indirect-transfer procedure with those from the direct-transfer procedure may not be done *a priori*. A site-specific intercomparison study must be done which takes into account the fibre size and type of asbestos, and also the nature of the source of the airborne asbestos.

Ambient air — Determination of asbestos fibres — Indirect-transfer transmission electron microscopy method

1 Scope

1.1 Substance determined

This International Standard specifies a reference method using transmission electron microscopy (TEM) for determination of the concentration of asbestos structures in ambient atmospheres. The specimen preparation procedure incorporates ashing and dispersion of the collected particulate, so that all asbestos is measured, including the asbestos originally incorporated in particle aggregates or particles of composite materials. The lengths, widths and aspect ratios of the asbestos fibres and bundles are measured, and these, together with the density of the type of asbestos, also allow the total mass concentration of airborne asbestos to be calculated. The method allows determination of the type(s) of asbestos fibre present. The method cannot discriminate between individual fibres of the asbestos and non-asbestos analogues of the same amphibole mineral.

1.2 Type of sample

The method is defined for polycarbonate capillary-pore filters or cellulose ester (either mixed esters of cellulose or cellulose nitrate) filters through which a known volume of air has been drawn. The method is suitable for determination of asbestos in both exterior and building atmospheres.

1.3 Range

The upper limit for the range of concentration that can be measured on the analytical filter is 7 000 structures/mm². The lower limit of the range that can be measured on the analytical filter corresponds to detection of 2,99 structures in the area of specimen examined. The air concentrations represented by these values are a function of the volume of air sampled and the degree of dilution or concentration selected during the specimen preparation procedures. The method is particularly applicable for measurements in areas with high suspended-particulate concentrations (exceeding 10 µg/m³), or where detection and identification of asbestos fibres are likely to be prevented or hindered by other types of particulate in direct-transfer TEM preparations. In theory, there is no lower limit to the dimensions of asbestos fibres which can be detected. In practice, microscopists vary in their ability to detect very small asbestos fibres. Therefore, a minimum length of 0,5 µm has been defined as the shortest fibre to be incorporated in the reported results.

1.4 Limit of detection

The limit of detection theoretically can be lowered indefinitely by filtration of progressively larger volumes of air, concentrating the sample during specimen preparation, and by extending the examination of the specimens in the electron microscope. In practice, the lowest achievable limit of detection for a particular area of TEM specimen examined is controlled by the total suspended particulate concentration remaining after the ashing and aqueous dispersal steps, and this depends on the chemical nature of the suspended particulate. For total suspended particulate concentrations of approximately 10 µg/m³, corresponding to clean, rural atmospheres, and assuming filtration of 4 000 litres of air, an analytical sensitivity of 0,5 structure/litre can be obtained, equivalent to a limit of detection of 1,8 structures/litre, if an area of 0,195 mm² of the TEM specimens is examined. Lower limits of detection can be achieved by increasing the area of the TEM specimen that is examined, or by concentration of the sample during specimen preparation. In order to achieve lower limits of detection for fibres and bundles longer than 5 µm, and for PCM-equivalent fibres, lower magnifications are specified which permit more rapid examination of larger areas of the TEM specimens when the examination is limited to these dimensions of fibre.

2 Terms and definitions

For the purposes of this International Standard, the following terms and definitions apply.

2.1

acicular

shape shown by an extremely slender crystal with cross-sectional dimensions which are small relative to its length, i.e. needle-like

2.2

amphibole

group of rock-forming ferromagnesium silicate minerals, closely related in crystal form and composition, and having the nominal formula:

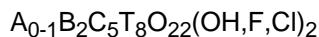

where

A is K, Na

B is Fe²⁺, Mn, Mg, Ca, Na

C is Al, Cr, Ti, Fe³⁺, Mg, Fe²⁺

T is Si, Al, Cr, Fe³⁺, Ti

NOTE In some varieties of amphibole, these elements can be partially substituted by Li, Pb, or Zn. Amphibole is characterized by a cross-linked double chain of Si-O tetrahedra with a silicon:oxygen ratio of 4:11, by columnar or fibrous prismatic crystals and by good prismatic cleavage in two directions parallel to the crystal faces and intersecting at angles of about 56° and 124°.

2.3

amphibole asbestos

amphibole in an asbestiform habit

2.4

analytical filter

filter through which an aqueous dispersion of ash from the sample collection filter is passed, and from which TEM specimen grids are prepared

2.5

analytical sensitivity

calculated airborne asbestos structure concentration, equivalent to counting of one asbestos structure in the analysis

NOTE 1 It is expressed in structures/litre.

NOTE 2 The method given in this International Standard does not specify an analytical sensitivity.

2.6

asbestiform

specific type of mineral fibrosity in which the fibres and fibrils possess high tensile strength and flexibility

2.7

asbestos

term applied to a group of silicate minerals belonging to the serpentine and amphibole groups which have crystallized in the asbestiform habit, causing them to be easily separated into long, thin, flexible, strong fibres when crushed or processed

NOTE The Chemical Abstracts Service Registry Numbers of the most common asbestos varieties are: chrysotile (12001-29-5), crocidolite (12001-28-4), grunerite asbestos (Amosite) (12172-73-5), anthophyllite asbestos (77536-67-5), tremolite asbestos (77536-68-6) and actinolite asbestos (77536-66-4).

2.8**asbestos structure**

term applied to an individual asbestos fibre, or any connected or overlapping grouping of asbestos fibres or bundles, with or without other particles

2.9**ashed filter blank**

fibre count made on TEM specimens prepared by the indirect procedure from a blank membrane filter of the type used for collection of air samples

2.10**aspect ratio**

ratio of length to width of a particle

2.11**blank**

structure count made on TEM specimens prepared from an unused filter in order to determine the background measurement

2.12**camera length**

equivalent projection length between the specimen and its electron diffraction pattern, in the absence of lens action

2.13**chrysotile**

fibrous mineral of the serpentine group which has the nominal composition

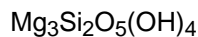

NOTE Most natural chrysotile deviates little from this nominal composition. In some varieties of chrysotile, minor substitution of silicon by Al^{3+} may occur. Minor substitution of magnesium by Al^{3+} , Fe^{2+} , Fe^{3+} , Ni^{2+} , Mn^{2+} and Co^{2+} may also be present. Chrysotile is the most prevalent type of asbestos.

2.14**cleavage**

breaking of a mineral along one of its crystallographic directions

2.15**cleavage fragment**

fragment of a crystal that is bounded by cleavage faces

2.16**cluster**

structure in which two or more fibres, or fibre bundles, are randomly oriented in a connected grouping

2.17**direct-transfer blank**

structure count made on TEM specimens prepared by the direct-transfer procedure from a blank filter of the type used for filtration of aqueous dispersions of ash

2.18**d-spacing**

distance between identical adjacent and parallel planes of atoms in a crystal

2.19**electron diffraction**

technique in electron microscopy by which the crystal structure of a specimen is examined

2.20**electron scattering power**

extent to which a thin layer of substance scatters impinging electrons from their original directions

2.21
empty beaker blank
fibre count made on TEM specimens prepared by the indirect procedure, using an empty beaker as the initial sample

2.22
energy-dispersive X-ray analysis
EDXA
measurement of the energies and intensities of X-rays by use of a solid-state detector and multichannel analyzer system

2.23
eucentric
condition in which the area of interest of an object is placed on a tilting axis, at the intersection of the electron beam with that axis, and is in the plane of focus

2.24
field blank
filter cassette which has been taken to the sampling site, opened and then closed, and the filter subsequently used to determine the background structure count for the measurement

2.25
fibril
single fibre of asbestos which cannot be further separated longitudinally into smaller components without losing its fibrous properties or appearances

2.26
fibre
elongated particle which has parallel or stepped sides

NOTE For the purposes of this International Standard, a fibre is defined to have an aspect ratio equal to or greater than 5:1 and a minimum length of 0,5 µm.

2.27
fibre bundle
structure composed of parallel, smaller-diameter fibres attached along their lengths

NOTE A fibre bundle may exhibit diverging fibres at one or both ends.

2.28
fibrous structure
fibre, or connected grouping of fibres, with or without other particles

2.29
funnel blank
structure count made on TEM specimens prepared by the direct-transfer method from a filter used for filtration of a sample of distilled water

2.30
habit
characteristic crystal growth form, or combination of these forms, of a mineral, including characteristic irregularities

2.31
limit of detection
calculated airborne asbestos structure concentration, equivalent to counting of 2,99 asbestos structures in the analysis

NOTE It is expressed in structures/litre.

2.32**matrix**

structure in which one or more fibres, or fibre bundles, touch, are attached to or partially concealed by, a single particle or connected group of nonfibrous particles

2.33**Miller index**

set of either three or four integer numbers used to specify the orientation of a crystallographic plane in relation to the crystal axes

2.34**PCM-equivalent fibre**

fibre of aspect ratio greater than or equal to 3:1, longer than 5 µm, and which has a diameter between 0,2 µm and 3,0 µm

NOTE For the purposes of this International Standard, PCM is the abbreviated term for phase-contrast optical microscopy.

2.35**PCM-equivalent structure**

fibrous structure of aspect ratio greater than or equal to 3:1, longer than 5 µm, and which has a diameter between 0,2 µm and 3,0 µm

NOTE For the purposes of this International Standard, PCM is the abbreviated term for phase-contrast optical microscopy.

2.36**primary structure**

fibrous structure that is a separate entity in the TEM image

2.37**replication**

procedure in electron microscopy specimen preparation in which a thin copy, or replica, of a surface is made

2.38**selected area electron diffraction**

technique in electron microscopy in which the crystal structure of a small area of a sample is examined

2.39**serpentine**

group of common rock-forming minerals having the nominal formula

**2.40****structure**

single fibre, fibre bundle, cluster or matrix

2.41**twinning**

occurrence of crystals of the same species joined together at a particular mutual orientation, and such that the relative orientations are related by a definite law

2.42**unopened fibre**

large diameter asbestos fibre bundle which has not been separated into its constituent fibrils or fibres

2.43**zone-axis**

line or crystallographic direction through the centre of a crystal which is parallel to the intersection edges of the crystal faces defining the crystal zone

3 Abbreviated terms

DMF	Dimethylformamide
ED	Electron diffraction
EDXA	Energy dispersive X-ray analysis
FWHM	Full width, half maximum
HEPA	High efficiency particle absolute
MEC	Mixed esters of cellulose
PC	Polycarbonate
PCM	Phase-contrast optical microscopy
SAED	Selected area electron diffraction
SEM	Scanning electron microscope
STEM	Scanning transmission electron microscope
TEM	Transmission electron microscope
UICC	Union Internationale Contre le Cancer

4 Principle

A sample of airborne particulate is collected by drawing a measured volume of air through either a capillary-pore polycarbonate (PC) membrane filter of maximum pore size 0,4 µm or a cellulose ester (either mixed esters of cellulose or cellulose nitrate) membrane filter of maximum pore size 0,8 µm by means of a battery-powered or mains-powered pump. A portion of the filter is ashed in an oxygen plasma, and the residual ash is dispersed in distilled water with adjustment of the pH to between 3,0 and 4,0 using acetic acid. Analytical filters are then prepared by filtration of known volumes of this aqueous dispersion through either capillary-pore PC membrane filters of maximum pore size 0,2 µm or cellulose ester membrane filters of maximum pore size 0,22 µm.

TEM specimens are prepared from PC analytical filters by applying a thin film of carbon to the filter surface by vacuum evaporation. Small areas are cut from the carbon-coated filter, supported on TEM specimen grids, and the filter medium is dissolved away by a solvent extraction procedure. This procedure leaves a thin film of carbon which bridges the openings in the TEM specimen grid, and which supports each particle from the original filter in its original position.

Cellulose ester analytical filters are chemically treated to collapse the pore structure of the filter, and the surface of the collapsed filter is then etched in an oxygen plasma to ensure that all particles are exposed. A thin film of carbon is evaporated onto the filter surface and small areas are cut from the filter. These sections are supported on TEM specimen grids and the filter medium is dissolved away by a solvent extraction procedure.

The TEM specimen grids from either preparation method are examined at both low and high magnifications to check that they are suitable for analysis before carrying out a quantitative fibre count on randomly-selected grid openings. If the selected TEM specimen grid has too high a particulate or fibre loading, another specimen grid with a lower filtered aliquot shall be selected for analysis. In the TEM analysis, electron diffraction (ED) is used to examine the crystal structure of a fibre, and its elemental composition is determined by energy-dispersive X-ray analysis (EDXA). For a number of reasons, it is not possible to identify each fibre unequivocally, and fibres are classified according to the techniques which have been used to identify them. A simple code is used to record, for each fibre, the manner in which it was classified. The fibre classification procedure is based on successive inspection of the morphology, the selected area ED pattern, and the qualitative and quantitative EDXAs. Confirmation of the identification of chrysotile is only by quantitative ED, and confirmation of amphibole is only by quantitative EDXA and quantitative zone-axis ED.

In addition to isolated fibres, ambient air samples often contain more complex aggregates of fibres, with or without other particles. Some particles are composites of asbestos fibres with other materials. Individual fibres and these more complex structures are referred to as "asbestos structures". The indirect specimen preparation procedure permits the majority of these complex structures to be dispersed into their constituent fibres and fibre bundles, allowing more precise quantification than is possible using the direct-transfer procedure.

A coding system is used to record the type of fibrous structure, and also to provide the optimum morphological description of each structure. The two codes remove from the microscopist the requirement to interpret the fibre counting data, and allow this evaluation to be made later without the requirement for re-examination of the TEM specimens. Several levels of analysis are specified, the higher levels providing a more rigorous approach to the identification of fibres. The procedure permits a minimum required fibre identification criterion to be defined on the basis of previous knowledge, or lack of it, about the particular sample. Attempts are then made to achieve this minimum criterion for each fibre, and the degree of success is recorded for each fibre. The lengths and widths of all classified structures are recorded.

The number of asbestos structures found on a known area of the microscope sample, together with the volume of air filtered through the sample collection filter, the proportion of the sample collection filter that was ashed, the proportion of the aqueous dispersion that was filtered, and the area of the analytical filter are used to calculate the airborne concentration of asbestos, expressed in asbestos structures/litre of air. The mass concentration of asbestos is calculated using an assumed density for the asbestos variety, and the widths and lengths of the fibres.

5 Apparatus

5.1 Air sampling

5.1.1 Filter cassette, for sample collection.

Field monitors, comprising 25 mm to 50 mm diameter three-piece cassettes with cowls which project less than 2 cm in front of the filter surface, shall be used for sample collection. The cassette shall be loaded with either a capillary pore PC filter of maximum pore size 0,4 µm or a cellulose ester [mixed esters of cellulose (MEC) or cellulose nitrate] filter of maximum pore size 0,8 µm. When the filter is in position, a shrink cellulose band or adhesive tape shall be applied to prevent air leakage. Suitable precautions shall be taken to ensure that the filters are tightly clamped in the assembly so that significant air leakage around the filter cannot occur.

Representative filters from the filter lot shall be analyzed as described in 8.8 for the presence of asbestos structures, and also tested for suitability as described in annex H, before any are used for air sample collection.

NOTE This method permits the use of larger pore size cellulose ester filters for sample collection than the maximum pore size permitted in the direct-transfer method in ISO 10312. The smaller maximum pore size is specified in ISO 10312 in order to ensure that collected particulate and fibres are retained close to the surface of the filter, which is required if the particulate and fibres are to be transferred to the TEM grid with high efficiency by the direct-transfer procedure. In this indirect-transfer method, the depth of penetration of particulate and fibres into the filter medium during sample collection is unimportant, provided that they do not pass through the filter.

5.1.2 Sampling pump, capable of a flowrate sufficient to achieve the desired analytical sensitivity. The face velocity through the filter shall be between 4,0 cm/s and 70 cm/s. The sampling pump used shall provide a nonfluctuating air flow through the filter, and shall maintain the initial volume flowrate to within $\pm 10\%$ throughout the sampling period. A constant-flow or critical-orifice controlled pump meets these requirements. Flexible tubing shall be used to connect the filter cassette to the sampling pump. A means for calibration of the flowrate of each pump is also required.

NOTE The sampling efficiency for a particular particle size varies with the face velocity. Depending on the size distribution of the airborne particles, the analytical result may vary with face velocity.

5.1.3 Stand, to hold the filter cassette at the desired height for sampling, isolated from the vibrations of the pump.

5.1.4 Variable area flowmeter, calibrated, with a range suitable for determination of the selected flowrate as required for calibration of the air sampling system.

5.2 Specimen preparation laboratory

Asbestos, particularly chrysotile, is present in varying quantities in many laboratory reagents. Many building materials also contain significant amounts of asbestos or other mineral fibres which may interfere with the analysis if they are inadvertently introduced during preparation of specimens. It is most important to ensure that during preparation, contamination of TEM specimens by any extraneous asbestos fibres is minimized. All specimen preparation steps shall therefore be performed in an environment where contamination of the sample is minimized. The primary requirement of the sample preparation laboratory is that a blank determination shall yield a result which will meet the requirements specified in 8.8. A minimum facility considered suitable for preparation of TEM specimens is a positive pressure, laminar flow hood. However, it has been established that work practices in specimen preparation appear to be more important than the type of clean handling facilities in use. Preparation of samples shall be carried out only after acceptable blank values have been demonstrated.

NOTE It is recommended that activities involving manipulation of bulk asbestos samples not be performed in the same area as TEM specimen preparation, because of the possibilities of contaminating the TEM specimens.

5.3 Equipment for analysis

5.3.1 Transmission electron microscope, operating at an accelerating potential of 80 kV to 120 kV, with a resolution better than 1,0 nm, and a magnification range of approximately 300× to 100 000× shall be used. The ability to obtain a direct screen magnification of about 100 000× is necessary for inspection of fibre morphology; this magnification may be obtained by supplementary optical enlargement of the screen image with a binocular if it cannot be obtained directly. The viewing screen shall be calibrated (such as shown in Figure 1) with concentric circles and a millimetre scale such that the lengths and widths of fibre images down to 1 mm width can be measured in increments of 1 mm.

For Bragg angles less than 0,01 rad the TEM shall be capable of performing ED from an area of 0,6 μm² or less, selected from an in-focus image at a screen magnification of 20 000×. This performance requirement defines the minimum separation between particles at which independent ED patterns can be obtained from each particle. If SAED is used, the performance of an individual instrument may normally be calculated using the following relationship:

$$A = 0,7854 \left(\frac{D}{M} + 2000 C_s \cdot \theta^3 \right)^2$$

where

A is the effective SAED area, expressed in square micrometres (μm²);

D is the diameter of the SAED aperture, expressed in micrometres;

M is the magnification of the objective lens;

C_s is the spherical aberration coefficient of the objective lens, expressed in millimetres;

θ is the maximum required Bragg angle, expressed in radians.

It is not possible to reduce the effective SAED area indefinitely by the use of progressively smaller SAED apertures, because there is a fundamental limitation imposed by the spherical aberration coefficient of the objective lens.

If zone-axis ED analyses are to be performed, the TEM shall incorporate a goniometer stage which permits the TEM specimen to be either:

- a) rotated through 360°, combined with tilting through at least +30° to −30° about an axis in the plane of the specimen; or,
- b) tilted through at least +30° to −30° about two perpendicular axes in the plane of the specimen.

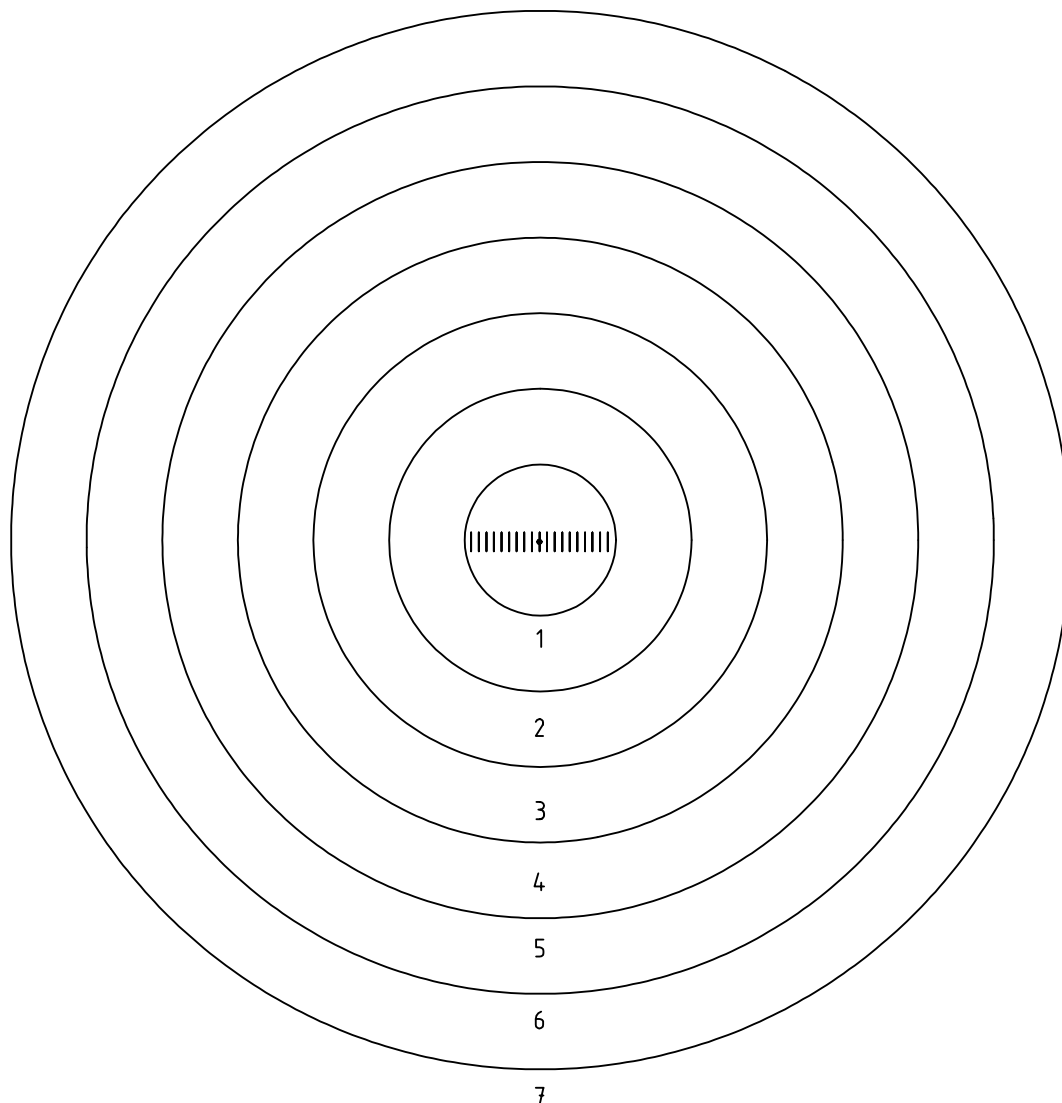

Figure 1 — Example of calibration markings on TEM viewing screen

The analysis is greatly facilitated if the goniometer permits eucentric tilting, although this is not essential. If EDXA and zone-axis ED are required on the same fibre, the goniometer shall be of a type which permits tilting of the specimen and acquisition of EDXA spectra without change of specimen holder.

The TEM shall have an illumination and condenser lens system capable of forming an electron probe smaller than 250 nm in diameter.

NOTE Use of an anticontamination trap around the specimen is recommended if the required instrumental performance is to be obtained.

5.3.2 Energy-dispersive X-ray analyzer, capable of achieving a resolution better than 180 eV (FWHM) on the $MnK\alpha$ peak. Since the performance of individual combinations of TEM and EDXA equipment is dependent on a number of geometrical factors, the required performance of the combination of the TEM and X-ray analyzer is specified in terms of the measured X-ray intensity obtained from a fibre of small diameter, using a known electron-beam diameter. Solid-state X-ray detectors are least sensitive in the low energy region, and so measurement of sodium in crocidolite shall be the performance criterion. The combination of electron microscope and X-ray analyzer shall yield, under routine analytical conditions, a background-subtracted $NaK\alpha$ integrated peak count rate of more than 1 count per second (cps) from a fibre of UICC crocidolite 50 nm in diameter or smaller when irradiated by an electron probe of 250 nm diameter or smaller at an accelerating potential of 80 kV. The peak/background ratio for this performance test shall exceed 1,0.

The EDXA unit shall provide the means for subtraction of the background, identification of element peaks, and calculation of background-subtracted peak areas.

5.3.3 Computer.

Many repetitive numerical calculations are necessary, and these may be performed conveniently by relatively simple computer programs. For analyses of zone-axis ED pattern measurements, a computer with adequate memory is required to accommodate the more complex programs involved.

5.3.4 Plasma asher, with a radio frequency power rating of 50 W or higher, for ashing of sample collection filters and for preparation of TEM specimens from MEC filters. The asher shall be supplied with a controlled oxygen flow, and shall be modified, if necessary, to provide a valve to control the speed of air admission so that rapid air admission does not disturb the particulate.

NOTE It is recommended that filters be fitted to the oxygen supply and the air admission line.

5.3.5 Vacuum coating unit, capable of producing a vacuum better than 0,013 Pa shall be used for vacuum deposition of carbon on the membrane filters. A sample holder is required which will allow a glass microscope slide to be continuously rotated during the coating procedure.

NOTE A mechanism which allows the rotating slide also to be tilted through an angle of approximately 45° during the coating procedure is recommended. A liquid nitrogen cold trap above the diffusion pump may be used to minimize the possibility of contamination of the filter surfaces by oil from the pumping system. The vacuum coating unit may also be used for deposition of the thin film of gold, or other calibration material, when it is required on TEM specimens as an internal calibration of ED patterns.

5.3.6 Sputter coater (optional), with a gold target, for deposition of gold onto TEM specimens as an internal calibration of ED patterns.

Other calibration materials are acceptable.

NOTE Experience has shown that a sputter coater allows better control of the thickness of the calibration material.

5.3.7 Beakers, of borosilicate glass, 50 ml capacity, as containers for plasma ashing of sample collection filters.

5.3.8 Vacuum source, to provide a vacuum of at least 20 kPa for the filtration of aqueous dispersions. A water jet pump is suitable.

5.3.9 Glass filtration apparatus, for the filtration of aqueous dispersions. This consists of a filtration base with a porous support for the filter, a reservoir with vertical sides, a clamp to hold the reservoir to the filtration base, and a vacuum flask or filtration manifold. A suitable apparatus is shown in Figure 2.

5.3.10 Solvent washer (Jaffe washer), to allow dissolution of the filter polymer while leaving an intact evaporated carbon film supporting the fibres and other particles from the filter surface. One design of a washer which has been found satisfactory for various solvents and filter media is shown in Figure 3.

In general, either chloroform or 1-methyl-2-pyrrolidone is used for dissolving PC filters and dimethylformamide or acetone is used for dissolving cellulose ester filters. The higher evaporation rates of chloroform and acetone require that a reservoir of 10 ml to 50 ml of solvent be used, which may need replenishment during the procedure. Dimethylformamide and 1-methyl-2-pyrrolidone have lower vapour pressures, therefore much smaller volumes of these solvents may be used. It is recommended that all washers be used in a fume hood, and when specimens are not being inserted or removed, during the solvent dissolution the Petri dish lid shall be in place. The washer shall be cleaned before it is used for each batch of specimens.

5.3.11 Condensation washer, for more rapid dissolution of the filter polymer, or if difficulties are experienced in dissolving the filter polymer. The washer shall consist of a flask, condenser and cold-finger assembly, with a heating mantle and means for controlling the temperature. A suitable assembly is shown in Figure 4, for use with either acetone or chloroform as the solvent, depending on the type of filter.

5.3.12 Slide warmer or oven, for heating slides during the preparation of TEM specimens from cellulose ester filters. It shall be capable of maintaining a temperature of 65 °C to 70 °C.

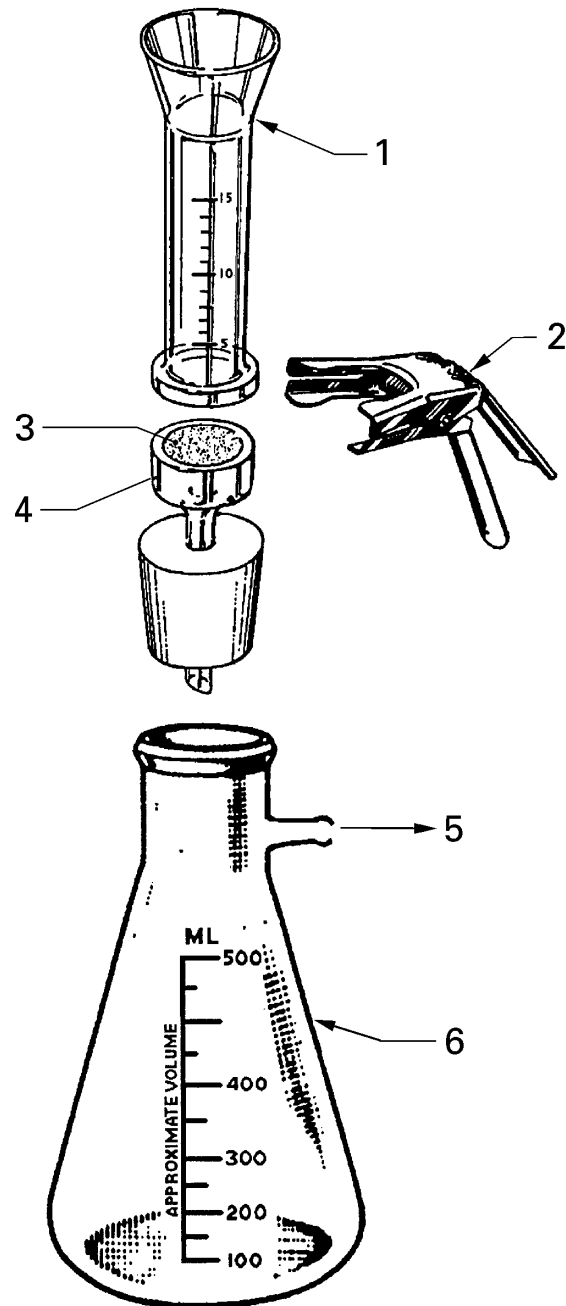

Key

- | | | | |
|---|----------------------|---|-----------------|
| 1 | Filtration reservoir | 4 | Filtration base |
| 2 | Clamp | 5 | Vacuum source |
| 3 | Porous support | 6 | Vacuum flask |

Figure 2 — Example of filtration apparatus

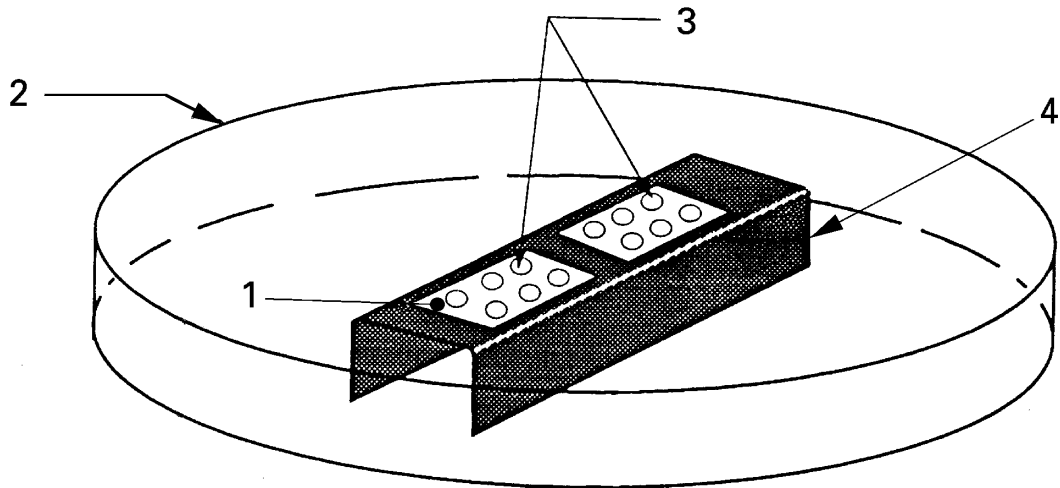

Key

- | | | | |
|---|-----------------------------------|---|---------------------------------------|
| 1 | Lens tissue | 3 | Electron microscope specimens |
| 2 | Glass Petri dish (100 mm × 15 mm) | 4 | Stainless steel mesh bridge (50 mesh) |

NOTE Solvent is added until the meniscus contacts the underside of the stainless steel mesh.

Figure 3 — Example of design of solvent washer (Jaffe washer)

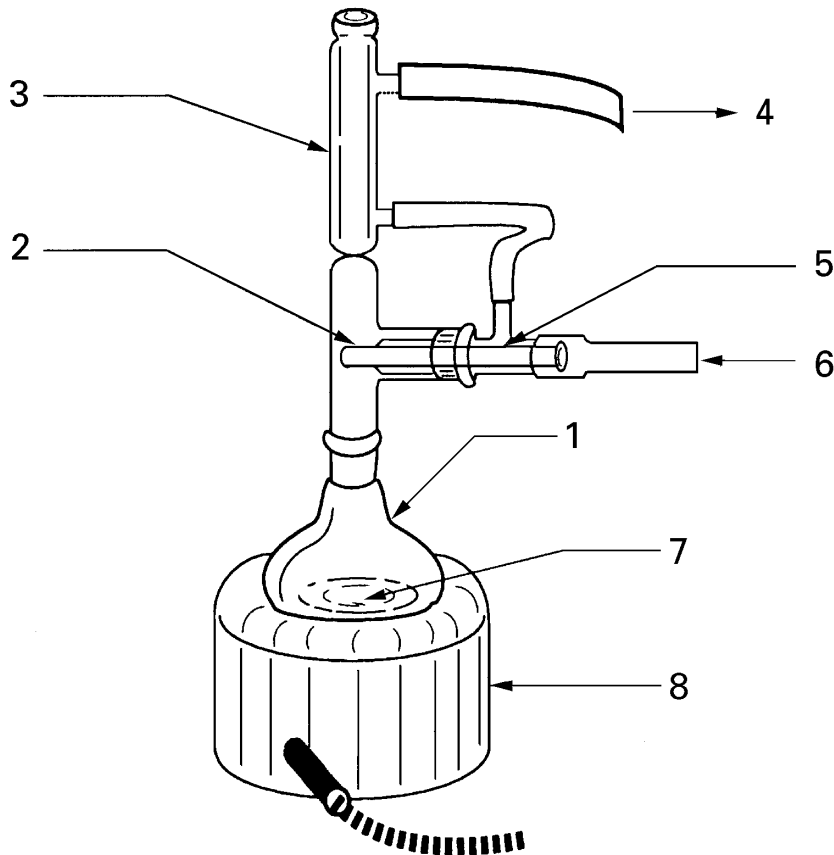

Key

- | | | | |
|---|-------------|---|--|
| 1 | Flask | 5 | Cold finger |
| 2 | Specimens | 6 | Cold water source |
| 3 | Condenser | 7 | Solvent |
| 4 | Water drain | 8 | Thermostatically controlled heating mantle |

Figure 4 — Design of condensation washer

Licensed to IATL/JOHN NAPOLITAN
 ISO Store order #:852310/Downloaded:2007-10-04
 Single user licence only, copying and networking prohibited

5.3.13 Ultrasonic bath, for aqueous dispersal of ash from sample collection filters, and also for cleaning of apparatus used for TEM specimen preparation. The power of the ultrasonic bath shall be sufficient to allow absorption of energy into a 40 ml volume of water in a 50 ml glass beaker at a rate between 0,05 W/ml to 0,1 W/ml, at a frequency of approximately 50 kHz.

5.3.14 Carbon-grating replica, with about 2 000 parallel lines per millimetre, to calibrate the magnification of the TEM.

5.3.15 Calibration grids for EDXA, prepared from dispersions of calibration minerals, for calibration of the EDXA system. Examples of suitable calibration minerals are riebeckite, chrysotile, halloysite, phlogopite, wollastonite and bustamite. Prepare the mineral used for calibration of the EDXA system for sodium using a gold TEM grid.

5.3.16 Carbon rod sharpener.

NOTE The use of necked carbon rods, or equivalent, allows the carbon to be evaporated on to the filters with a minimum of heating.

5.3.17 Disposable-tip micropipettes, capable of transferring a volume of approximately 50 µl for the pH adjustment, and a volume of approximately 30 µl for the preparation of TEM specimen grids from cellulose ester filters.

5.3.18 Thermometer, with a range from 0 °C to 100 °C, for calibration of the ultrasonic bath.

5.3.19 Stopwatch, for calibration of the ultrasonic bath.

5.4 Consumable supplies

5.4.1 Cellulose ester filters (either MEC or cellulose nitrate) filters of maximum pore size 0,22 µm and diameter appropriate for the liquid filtration apparatus, for filtration of the aqueous suspension of residual ash.

5.4.2 Cellulose ester filters (either MEC or cellulose nitrate) of 5 µm pore size and diameter appropriate for the liquid filtration apparatus, for use with the liquid filtration apparatus.

5.4.3 Polycarbonate filters, of maximum pore size 0,2 µm and diameter appropriate for the liquid filtration apparatus, for filtration of the aqueous suspension of residual ash.

5.4.4 Petri dishes, for storage of analytical filters prepared by filtration of the suspension of residual ash.

5.4.5 Copper electron-microscope grids.

Two hundred mesh TEM grids are recommended. Grids which have grid openings of uniform size such that they meet the requirement of 8.7.2 shall be chosen. To facilitate the relocation of individual grid openings for quality assurance purposes, the use of grids with numerical or alphabetical indexing of individual grid openings is recommended.

5.4.6 Gold electron-microscope grids.

Two-hundred-mesh gold TEM grids are recommended to mount TEM specimens when sodium measurements are required in the fibre identification procedure. Grids which have grid openings of uniform size such that they meet the requirement of 8.7.2 shall be chosen. To facilitate the relocation of individual grid openings for quality assurance purposes, the use of grids with numerical or alphabetical indexing of individual grid openings is recommended.

5.4.7 Aluminium foil, for covering beakers during the plasma ashing and ultrasonic treatment steps. Aluminium foil of 0,015 mm to 0,020 mm thickness is suitable.

5.4.8 Carbon rod electrodes, spectrochemically pure, for use in the vacuum evaporator during carbon coating of filters.

5.4.9 Routine electron microscopy tools and supplies, including fine-point tweezers, scalpel holders and blades, microscope slides, double-sided adhesive tape, lens tissue, gold wire, tungsten filaments and other routine supplies are required.

5.4.10 Reference asbestos samples, for preparation of reference TEM specimens of the primary asbestos minerals. The UICC set of minerals is suitable for this purpose.

6 Reagents

WARNING — Use the reagents in accordance with the appropriate health and safety regulations.

- 6.1 Fibre-free water**, freshly distilled, or other source of fibre-free, pyrogen-free water shall be used.
- 6.2 Chloroform**, analytical grade, distilled in glass [preserved with 1 % (volume fraction) ethanol].
- 6.3 1-Methyl-2-pyrrolidone**, analytical grade.
- 6.4 1,2-Diaminoethane**, analytical grade.
- 6.5 Dimethylformamide**, analytical grade.
- 6.6 Glacial acetic acid**, analytical grade.
- 6.7 Acetone**, analytical grade.

7 Air sample collection

7.1 Calculation of analytical sensitivity

The desired analytical sensitivity is a parameter that shall be established for the analysis prior to sample collection. The analytical sensitivity is defined as that structure concentration corresponding to the detection of one structure in the analysis. For indirect-transfer methods of TEM specimen preparation, it is a function of the volume of air sampled, the active area of the collection filter, the area of the collection filter that is ashed, the proportion of the aqueous dispersion of ash that is filtered, the area of the analytical filter, and the area of the TEM specimen over which structures are counted. The number of grid openings, k , required to be examined to achieve a particular analytical sensitivity is calculated using the formula:

$$k = \frac{(A_a \cdot V_d)}{(S \cdot A_g \cdot V_f \cdot F_a \cdot V_s)}$$

where

- A_a is the active area, expressed in square millimetres, of analytical filter;
- V_d is the volume, expressed in millilitres, of water used for dispersal of residual ash;
- S is the analytical sensitivity, expressed in structures/litre;
- A_g is the mean area of grid openings, expressed in square millimetres;
- V_f is the volume, expressed in millilitres, of aqueous dispersion filtered;
- F_a is the fraction of sample collection filter ashed;
- V_s is the volume, expressed in litres, of air sampled.

Examples of the number of grid openings required to be examined, using various combinations of sampling and analytical parameters, are shown in Table 1.

Table 1 — Examples of minimum number of grid openings required to achieve a particular analytical sensitivity and limit of detection

Analytical sensitivity structures/litre	Limit of detection structures/litre	Minimum number of grid openings						
		Litres of air sampled						
		500	1 000	2 000	3 000	4 000	5 000	10 000
0,1	0,3	1 297	649	325	217	163	130	65
0,2	0,6	649	325	163	109	82	65	33
0,3	0,9	433	217	109	73	55	44	22
0,4	1,2	325	163	82	55	41	33	17
0,5	1,5	260	130	65	44	33	26	13
0,7	2,1	186	93	47	31	24	19	10
1,0	3,0	130	65	33	22	17	13	7
2,0	6,0	65	33	17	11	9	7	4
3,0	9,0	44	22	11	8	6	5	4
4,0	12	33	17	9	6	5	4	4
5,0	15	26	13	7	5	4	4	4
7,0	21	19	10	5	4	4	4	4
10	30	13	7	4	4	4	4	4

NOTE In Table 1, it is assumed that one half of the sample collection filter is ashed, the volume of water used to disperse the ash is 40 ml, the volume of aqueous dispersion filtered is 34 ml, the active area of the analytical filter is 199 mm², and the TEM grid openings are square with a linear dimension of 85 µm. The limit of detection is defined as the upper 95 % confidence limit of the Poisson distribution for a count of zero structures. In the absence of background, this is equal to 2,99 times the analytical sensitivity. Non-zero backgrounds observed during analysis of blank filters will degrade the limit of detection.

7.2 Sample collection procedure

Air samples shall be collected using cassettes as described in 5.1.1. During sampling, the filter cassette shall be supported on a stand which is isolated from the vibrations of the pump. The cassette shall be held facing vertically downwards at a height of approximately 1,5 m to 2,0 m above ground/floor level, and connected to the pump with a flexible tube. Measure the sampling flowrate at the front end of the cassette, both at the beginning and end of the sampling period, using a calibrated variable-area flowmeter temporarily attached to the inlet of the cassette. The mean value of these two measurements shall be used to calculate the total air volume sampled.

The variable area flowmeter shall be cleaned before use, to avoid transfer of fibre contamination from the flowmeter to the sample being collected.

Basic strategies for monitoring environmental sources of airborne asbestos are described in annex I. After sampling, a cap shall be placed over the open end of the cassette, and the cassette packed with the filter face-upwards for return to the laboratory. Field blank filters shall also be included, as described in 8.8, and processed through the remaining analytical procedures along with the samples.

8 Procedure for analysis

8.1 General

The procedures for ashing of sample collection filters, dispersion of the residual ash, and filtration of the aqueous dispersion are identical for the two types of sample collection filter. The techniques used to prepare TEM specimens from the analytical filters are different for PC and cellulose ester filters. The preparation method to be used shall be

that described in either 8.4 or 8.5, depending on the type of membrane filter used for filtration of the aqueous dispersions. Cleaning of the sample cassettes before they are opened, preparation of the carbon evaporator, criteria for acceptable specimen grids, and the requirement for blank determinations are identical for the two preparation techniques. TEM examination, structure counting, fibre identification and reporting of results are independent of the type of filter or preparation technique used.

The ability to meet the blank sample criteria is dependent on the cleanliness of equipment and supplies. Consider all supplies, such as microscope slides and glassware, as potential sources of asbestos contamination. It is necessary to wash all glassware before it is used. Wash any tools or glassware which come into contact with the air sampling filters or TEM specimen preparations both before use, and between handling of individual samples. Where possible, use disposable supplies.

NOTE In order to ensure that all particulate contamination and fibres are detached from glassware, it is recommended that all surfaces be washed by rubbing vigorously with clean paper towel soaked in detergent, and rinsed several times under a continuous flow of water. The glassware should then be rinsed at least twice using fibre-free water.

8.2 Cleaning of sample cassettes

Asbestos fibres can adhere to the exterior surfaces of air-sampling cassettes, and these fibres can be inadvertently transferred to the sample during handling. To prevent this possibility of contamination, and after ensuring that the cassette is tightly sealed, wipe the exterior surfaces of each sampling cassette with wet paper towel before it is taken into the clean facility or laminar-flow hood.

8.3 Preparation of analytical filters

8.3.1 Selection of filter area for ashing

Depending on the analytical sensitivity to be achieved, ash either a quarter or a half of the sample collection filter. Using freshly cleaned tweezers, remove the sample collection filter from the sampling cassette, and place it onto a second cleaned glass microscope slide which is used as a cutting surface. Using a freshly-cleaned curved scalpel blade, cut the required area of the filter by rocking the blade from the point, pressing it into contact with the filter. Repeat the process as necessary.

8.3.2 Ashing of sample collection filters

Place the selected filter portion into a 50 ml borosilicate glass beaker, ensuring that the side of the filter with the collected particulate faces downwards. Cover the beaker with a 6 cm × 6 cm square piece of aluminium foil of thickness 0,015 mm to 0,02 mm, and bend the foil over the edges of the beaker so that it forms a tight seal. Perforate the foil in 10 to 20 positions with a needle to allow for gas exchange during plasma ashing. Depending on the size of the plasma asher chamber, several sample filters may be ashed simultaneously. At least one empty beaker, prepared in the same way, shall be placed in the asher chamber along with each batch of samples ashed. Operate the plasma asher using the minimum power at which a glow discharge is observed, until the filters appear to be completely ashed. Increase the plasma asher power to the maximum, and operate under these conditions for a minimum period of 3 h. After the ashing treatment is completed, admit air to the chamber and remove the beakers.

NOTE Losses of particulate and fibres from the beaker will occur if the plasma asher is operated at excessive radio-frequency power. During ashing of MEC or cellulose nitrate filters, a critical point is reached during the oxidation at which a sudden, violent ignition occurs if the radio-frequency power is excessive. This results in loss of fibres from the beaker, contamination of the interior surfaces of the chamber, and possible cross-contamination of the samples. The same considerations apply to the ashing of PC filters. The ashing procedure specified avoids these problems. It is recommended that the ashing of a blank filter be observed closely during the final stages of oxidation, in order to ensure that the radio-frequency power setting is such that a sudden ignition does not occur.

8.3.3 Aqueous dispersal of residual ash from sample collection filters

Remove the aluminium foil from the top of the beaker. Using a disposable-tip pipette, add 50 µl of glacial acetic acid, and then add 40 ml of freshly distilled water. Cover the beaker with a new 6 cm × 6 cm square piece of aluminium foil, and bend the foil over the edges of the beaker so that it forms a tight seal. Place the beaker into the ultrasonic bath and operate the bath at the calibrated power (see annex B) for a period of 5 min.

8.3.4 Assembly of system for filtration of aqueous dispersions

Filtration of the aqueous dispersions is a very critical procedure because it is important to obtain uniform deposits of particulate on the analytical filters. The following procedure shall be used.

- a) Set up the filtration system and connect to a vacuum source;
- b) add freshly distilled water to the filtration unit base component until there is a raised meniscus;
- c) place a 5 µm pore size cellulose ester filter onto the water meniscus. The filter will centralize. Apply the vacuum very briefly in order to bring the filter into contact with the base component;
- d) add freshly distilled water to the top of the cellulose ester filter, and place the analytical filter (either a 0,2 µm maximum pore size capillary-pore PC filter or a 0,22 µm maximum pore size cellulose ester filter) onto the water surface. Apply the vacuum very briefly again in order to bring both filters into contact with the base component;
- e) install the filtration reservoir and clamp the assembly together.

8.3.5 Filtration of aqueous dispersions

Before filtering the aqueous dispersions, prepare a funnel blank by filtration of 40 ml of freshly distilled water.

The volume of the aqueous dispersion to be filtered depends on either the particulate concentration or the asbestos fiber concentration. The volume of aqueous dispersion required to produce an analytical filter with a suitable particulate or fiber loading for analysis often cannot be predicted, and it is usually necessary to prepare several analytical filters corresponding to filtration of different aliquots. The aqueous dispersions are not stable, and extended exposure of chrysotile to acidic environments causes leaching of magnesium to occur from the fibres; it is therefore necessary to prepare all analytical filters immediately. Uniform deposits of particulate on the analytical filters cannot be assured if liquid volumes smaller than 5 ml are filtered using filtration systems of 199 mm² active area; accordingly, where it is required to filter volumes smaller than 5 ml, the aliquot shall be diluted with freshly distilled water to a volume exceeding 5 ml.

Pour the aliquot of the dispersion into the filtration reservoir, and apply the vacuum. If the volume of the aliquot is larger than the capacity of the filtration reservoir, do not allow the level of liquid in the reservoir to fall below 5 cm depth before the remaining volume is added. Failure to observe this precaution may result in disturbance of the filtered particulate and non-uniform deposition.

With the vacuum still applied, unclamp the filtration assembly and remove the filtration reservoir. Using clean tweezers, remove the analytical filter and transfer it to a Petri dish. Allow the filter to dry before placing the cover on the Petri dish.

For the beaker blank, prepare only one analytical filter by filtration of the entire 40 ml dispersion.

NOTE It is recommended that analytical filters corresponding to volumes of 1 ml, 5 ml and 34 ml be prepared, unless there is reason to suspect that even the lowest volume will yield an analytical filter of unacceptably high loading. If the particulate or fiber concentration is thought to be such that it is required to filter an aliquot of volume lower than 1 ml, use a dilution procedure in which 1 ml of the original dispersion is transferred to a clean beaker and diluted with freshly distilled water to a total volume of 100 ml. After stirring to ensure complete mixing, aliquots of 10 ml and 30 ml from this diluted dispersion can then be filtered, corresponding to volumes of 0,1 ml and 0,3 ml of the original dispersion. From the original dispersion, volumes of 1 ml, 5 ml and 33 ml are also filtered, giving five analytical filters with a concentration range of a factor of 330. The requirement for washing of the filtration apparatus is minimized if the aliquots are filtered in order of increasing concentration. If aqueous dispersions are known to have high concentrations of asbestos fibres, the level of cross-contamination from one sample to the next can be determined by interposing additional funnel blanks. Wash the filtration apparatus between filtrations of different samples.

8.4 Preparation of TEM specimens from PC analytical filters

8.4.1 Selection of filter area for carbon-coating

Use a cleaned microscope slide to support representative portions of polycarbonate (PC) filter during the carbon evaporation. Double-sided adhesive tape is used to hold the filter portions to the glass slide. Take care not to

stretch the PC filters during handling. Using freshly cleaned tweezers, remove the PC filter from the Petri dish, and place it on a second cleaned glass microscope slide which is used as a cutting surface. Using a freshly-cleaned curved scalpel blade, cut the filter by rocking the blade from the point, pressing it into contact with the filter. Repeat the process as necessary. Several such portions may be mounted on the same microscope slide. The scalpel blade and tweezers shall be washed and dried between the handling of each filter. Identify the filter portions by writing on the glass slide.

8.4.2 Carbon-coating of filter portions

Place the glass slide holding the filter portions on the rotating-tilting device, approximately 10 cm to 12 cm from the evaporation source, and evacuate the evaporator chamber to a vacuum better than 0,013 Pa. The evaporation of carbon shall be performed in very short bursts, separated by a few seconds to allow the electrodes to cool. If evaporation of carbon is too rapid, the strips of PC filter will begin to curl, and crosslinking of the surface will occur. This crosslinking produces a layer of polymer which is relatively insoluble in chloroform, and it will not be possible to prepare satisfactory TEM specimens. The thickness of carbon required is dependent on the size of particles on the filter; approximately 30 nm to 50 nm has been found to be satisfactory. If the carbon film is too thin, large particles will break out of the film during the later stages of preparation, and there will be few complete and undamaged grid openings on the specimen. Too thick a carbon film will lead to a TEM image which is lacking in contrast, and the ability to obtain ED patterns will be compromised. The carbon film thickness should be the minimum possible, while retaining most of the grid openings of the TEM specimen intact.

8.4.3 Use of the Jaffe washer

Place several pieces of lens tissue, as shown in Figure 3, on the stainless steel bridge, and fill the washer with chloroform or 1-methyl-2-pyrrolidone to a level where the meniscus contacts the underside of the mesh, resulting in saturation of the lens tissue.

Using a curved scalpel blade, cut three 3 mm square pieces of carbon-coated PC filter from the carbon-coated filter portion. Select three squares to represent the centre and the outer periphery of the active surface of the filter. Place each square of filter, carbon side up, on a TEM specimen grid, and place the grid and filter onto the saturated lens tissue in the Jaffe washer. Place the three specimen grids from one sample on the same piece of lens tissue. Any number of separate pieces of lens tissue may be placed in the same Jaffe washer. Cover the Jaffe washer with the lid, and allow the washer to stand for at least 8 h.

NOTE It has been found that some PC filters will not completely dissolve in the Jaffe washer, even after exposure to chloroform for as long as 3 days. This problem is more severe if the surface of the filter was overheated during the carbon evaporation. It has been found that the problem of residual undissolved filter polymer can be overcome in several ways:

- a) a mixture of 20 % 1,2-diaminoethane (ethylenediamine) and 80 % 1-methyl-2-pyrrolidone, used in a Jaffe washer, completely dissolves PC filters in 15 min, even if the surface of the filter has been overheated. To use this solvent, place the grids directly on the stainless steel mesh of the Jaffe washer; do not use the lens paper. After a period of 15 min, transfer the stainless steel bridge into another Petri dish, and add distilled water until the meniscus contacts the underside of the mesh. After approximately 15 min, remove the mesh and allow the grids to dry;
- b) used in a Jaffe washer, 1-methyl-2-pyrrolidone has been found to be a more effective solvent than chloroform for PC filters. This solvent is more effective if the lens paper not used and grids are placed directly on the stainless steel mesh of the Jaffe washer. A dissolution period of 2 h to 6 h has been found to be satisfactory. After dissolution is complete, remove the stainless steel mesh from the Jaffe washer and allow the grids to dry. 1-Methyl-2-pyrrolidone evaporates very slowly. If it is required to dry the grids more rapidly, transfer the stainless steel bridge into another Petri dish, and add distilled water until the meniscus contacts the underside of the mesh. After approximately 15 min, remove the mesh and allow the grids to dry;
- c) condensation washing of the grids, using chloroform as the solvent, after the initial Jaffe washer treatment, can often remove much of the residual filter medium in a period of approximately 30 min. To carry out this procedure, transfer the piece of lens tissue supporting the specimen grids to the cold finger of the condensation washer, which has achieved stable operating conditions. Operate the washer for approximately 30 min after inserting the grids.

8.4.4 Rapid preparation of TEM specimens from PC filters

TEM specimens can be prepared rapidly from PC filters, if desired, using the filter dissolution procedure described in item a) of the note in 8.4.3. Alternatively, the specimens may be washed for approximately 1 h in a Jaffe washer, followed by washing for 30 min in a condensation washer using chloroform as the solvent.

8.5 Preparation of TEM specimens from cellulose ester analytical filters

8.5.1 Selection of area of filter for preparation

Using clean tweezers, remove the filter from the Petri dish, and place it on a cleaned microscope slide. Using a clean, curved scalpel blade, cut out a portion of the filter.

8.5.2 Preparation of solution for collapsing cellulose ester filters

Mix 35 ml of dimethylformamide, 15 ml of glacial acetic acid and 50 ml of freshly distilled water. Store this mixture in a clean bottle. The mixture is stable and suitable for use for up to 3 months after preparation.

8.5.3 Filter-collapsing procedure

Using a micropipette with a disposable tip, place 15 $\mu\text{l}/\text{cm}^2$ to 25 $\mu\text{l}/\text{cm}^2$ of the collapsing solution on a cleaned microscope slide and, using the end of the pipette tip, spread the liquid over the area to be occupied by the filter portion. Place the filter portion, active surface upwards, on top of the solution, lowering the edge of the filter at an angle of about 20° so that air bubbles are not created. Remove any solution not absorbed by the filter by allowing a paper tissue to contact the liquid at the edge of the filter. More than one filter portion may be placed on one slide. Place the slide either on a thermostatically controlled slide warmer at a temperature of 65 °C to 70 °C, or in an oven at this temperature, for 10 min. The filter collapses slowly to about 15 % of its original thickness. The procedure leaves a thin, transparent polymer film, with particles and fibres embedded in the upper surface.

8.5.4 Plasma etching of the filter surface

The conditions required in the particular plasma asher shall be established using the procedure defined in annex A. Place the microscope slide holding the collapsed filter portions in the plasma asher, and etch for the time and under the conditions determined. Take care to ensure that the correct conditions are used. After etching, admit air slowly to the chamber and remove the microscope slide.

The air admission valve of the plasma asher shall be adjusted such that the time taken for the chamber to reach atmospheric pressure exceeds 2 min. Rapid air admission may disturb particulate on the surface of the etched filter.

8.5.5 Carbon-coating

Carbon-coat the microscope slide holding the collapsed filter portions as described in 8.4.2.

8.5.6 Use of the Jaffe washer

Place several pieces of lens tissue on the stainless steel bridge, and fill the washer with dimethylformamide or acetone to a level where the meniscus contacts the underside of the mesh, resulting in saturation of the lens tissue.

Place the specimens in the Jaffe washer as described in 8.4.3. Specimens are normally cleared after approximately 4 h.

8.5.7 Rapid preparation of TEM specimens from cellulose ester filters

An alternative washing procedure may be used to prepare TEM specimens from cellulose ester filters more rapidly than can be achieved by the Jaffe washing procedure. After the specimens have been washed in a Jaffe washer for approximately 1 h, transfer the piece of lens tissue supporting the specimens to the cold finger of a condensation washer operating with acetone as the solvent. Operate the condensation washer for approximately 30 min. This treatment removes all remaining filter polymer.

Dimethylformamide shall not be used in a condensation washer.

8.6 Criteria for acceptable TEM specimen grids

Valid data cannot be obtained unless the TEM specimens meet specified quality criteria. Incomplete dispersion of the residual ash from the sample collection filter, or non-uniform deposition of particulate due to the use of incorrect filtration procedures are of major concern. Examine in the TEM all three of the TEM grids corresponding to the largest filtered aliquot at a magnification sufficiently low ($300\times$ to $1\,000\times$) so that complete grid openings can be inspected. If large areas of undispersed ash are observed on widely separated grid openings, the sample collection filter was either incompletely ashed, or the filter medium may be unsuitable for this preparation procedure. Reject all of the filters and grids. If it is suspected that the filters are unsuitable for this analytical procedure, use the procedure specified in annex H to confirm that the filter medium is suitable for analysis by this method, and reprepare the sample from another sector of the sample collection filter.

If the particulate deposit on the TEM grids corresponding to filtration of the largest filtered aliquot appears to be uniform, it is then necessary to select the set of TEM grids with an appropriate loading for fibre counting. Reject the grids if:

- a) the carbon replica covers less than approximately 75 % of the area of the TEM specimen grids;
- b) the TEM specimen has not been cleared of filter medium by the filter dissolution step;

If the TEM specimen exhibits areas of undissolved filter medium, and if at least two of the three specimen grids are not cleared, either additional solvent washing shall be carried out, or new specimens shall be prepared from the analytical filter.

- c) the sample is overloaded with particulate;

If the specimen grid exhibits more than approximately 10 % obscuration on the majority of the grid openings, the specimen shall be designated as over-loaded. This filter cannot be analyzed satisfactorily because the grid is too heavily loaded with debris to allow separate examination of individual particles by ED and EDXA, and obscuration of fibres by other particulate may lead to under-estimation of the structure count. Specimens prepared from a filter corresponding to filtration of a smaller aliquot shall be selected.

- d) the particulate deposits on the specimen are not uniformly distributed from one grid opening to the next;

If the particulate deposits on the specimen are obviously not uniform from one grid opening to the next, the specimen shall be designated as non-uniform. This condition is caused by incorrect installation of the filters for filtration of the aqueous dispersions, or inadequate mixing during dilution of a small volume aliquot. Satisfactory analysis of this filter may not be possible unless a large number of grid openings is examined.

- e) the TEM grid is too heavily loaded with fibrous structures to make an accurate count;

Accurate counts cannot be made if the grid has more than approximately 7 000 structures/mm². Select specimens prepared from a filter corresponding to filtration of a smaller aliquot.

- f) more than approximately 25 % of the grid openings have broken carbon film over the whole grid opening;

Since the breakage of carbon film is usually more frequent in areas of heavy deposit, counting of the intact openings can lead to an underestimate of the structure count. Prepare specimens from another sector of the analytical filter, or select grids corresponding to filtration of a smaller aliquot.

If the specimens are rejected because unacceptable numbers of grid openings exhibit broken carbon replica, an additional carbon coating may be applied to the carbon-coated filter, and new specimen grids prepared. The larger particles can often be supported by using a thicker carbon film. If this action does not produce acceptable specimen grids, this filter cannot be analyzed and grids prepared from an analytical filter with a lower particulate loading shall be selected.

8.7 Procedure for structure counting by TEM

8.7.1 General

The examination consists of a count of asbestos structures which are present on a specified number of grid openings. Fibrous structures are classified into groups on the basis of morphological observations, ED patterns and EDXA spectra. The total number of asbestos structures to be counted depends on the statistical precision desired. In the absence of asbestos structures, the area of the TEM specimen grids to be examined depends on the analytical sensitivity required. The precision of the structure count depends not only on the total number of structures counted, but also on their uniformity from one grid opening to the next. Additional structure counting will be necessary if greater precision is required.

In order that the estimate of the structure density on the sampling filter is not based on the structure deposits found within the small area represented by one specimen grid, examine grid openings on two of the three specimen grids prepared. Then combine the results for the calculation of the structure density. Make structure counts at a magnification of approximately 20 000×, and terminate at the end of the examination of the grid opening on which the 100th asbestos structure is observed, except continue the count until a minimum of four grid openings have been examined. Otherwise, continue the structure count to that number of grid openings at which the specified analytical sensitivity has been achieved.

NOTE The normal range for the number of grid openings which should be examined is from 4 to 20. If insufficient air has been sampled through the filter, the calculation in 8.7.4 can indicate that an impractically large number of grid openings should be examined. When this situation occurs, a larger value of analytical sensitivity may have to be accepted.

8.7.2 Measurement of mean grid-opening area

Measure the mean grid-opening area for the type of TEM specimen grid in use. The standard deviation of the mean of 10 openings selected from 10 grids should be less than 5 %. Optionally, or if the 5 % standard deviation criterion cannot be demonstrated, measure at a calibrated magnification the dimensions of each grid opening examined in the TEM.

8.7.3 TEM alignment and calibration procedures

Before structure counting is performed, align the TEM according to instrumental specifications. Calibrate the TEM and EDXA system according to the procedures in annex C.

8.7.4 Determination of stopping point

Before structure counting is begun, calculate the area of specimen to be examined in order to achieve the selected analytical sensitivity. Calculate the maximum number of grid openings to be examined, using the formula:

$$k = \frac{(A_a \cdot V_d)}{(S \cdot A_g \cdot V_f \cdot F_a \cdot V_s)}$$

where

- k is the number of grid openings to be examined, rounded to the next highest integer;
- A_a is the area, expressed in square millimetres (mm²), of sample filter;
- V_d is the volume, expressed in millilitres (ml), of water used for dispersal of residual ash;
- S is the required analytical sensitivity, expressed in structures/litre;
- A_g is the area, expressed in square millimetres (mm²), of TEM specimen grid opening;
- V_f is the volume, expressed in millilitres (ml), of aqueous dispersion filtered;
- F_a is the fraction of sample collection filter ashed;
- V_s is the volume, expressed in litres (l), of air sampled.

8.7.5 General procedure for structure counting and size analysis

Use at least two specimen grids prepared from the filter in the structure count. Select at random several grid openings from each grid, and combine the data in the calculation of the results.

Use a form similar to that shown in Figure 5 to record the structure-counting data. Insert the first specimen grid into the TEM.

In order to facilitate quality assurance measurements which require re-examination of the same grid opening by different microscopists, insert the grid into the specimen holder in a standard orientation with the grid bars parallel and perpendicular to the axis of the specimen holder. This will provide scan directions parallel to the edges of the grid opening. Ensure that all microscopists begin scanning at the same starting point on the grid opening, and that they use similar scan patterns. This procedure permits rapid relocation of fibrous structures for further examination if necessary.

Select a typical grid opening and set the screen magnification to the calibrated value (approximately 20 000 \times). Adjust the sample height until the features in the centre of the TEM viewing screen are at the eucentric point. Set the goniometer tilt angle to zero. In column 1 of the structure-counting form, record the number or letter used to identify the grid. In column 2, record the identification of the particular grid opening. Position the specimen so that the grid opening is positioned with one corner visible on the screen. Move the image by adjustment of only one translation control, carefully examining the sample for fibrous structures, until the opposite side of the grid opening is encountered. Move the image by a predetermined distance less than one screen diameter, using the other translation control, and scan the image in the reverse direction. Continue the procedure in this manner until the entire grid opening has been inspected in a pattern similar to that shown in Figure 6.

When a fibrous structure is detected, assign a sequential number to the primary structure in column 3, perform the identification procedures required as detailed in annex E, and enter the appropriate compositional classification on the structure counting form in column 5. Assign a morphological classification to the structure according to the procedures in annex D, and record this in column 6. Measure on the TEM viewing screen the length and width of the image of the primary structure, in millimetres, and record these measurements in columns 7 and 8. For a disperse cluster or matrix, assign a compositional classification and a morphological classification to each structure component, measure the length and width, and enter the data in columns 4 to 8. Use column 4 of the structure-counting form to tabulate the sequential number of total structures, taking into account structure components. If non-asbestos fibres are observed, note their presence and type, if known.

After a fibrous structure has been examined and measured, relocate the original field of view accurately before continuing scanning of the specimen. Failure to do this may cause fibres to be overlooked or counted twice. Continue the examination until the completion of the grid opening on which the 100th fibrous structure has been recorded, or until the number of grid openings required to achieve the specified analytical sensitivity, calculated according to 8.7.4, have been examined, whichever occurs first. The data shall be drawn approximately equally from a minimum of two grids. Regardless of the value calculated according to 8.7.4, fibrous structures on a minimum of four grid openings shall be counted.

8.7.6 Measurement of concentration of asbestos fibres and bundles longer than 5 μm

Give consideration to improving the statistical validity for measurement of asbestos fibres and bundles longer than 5 μm by additional examination of the TEM specimens at a lower magnification, taking account only of these long fibres and bundles. Perform this extended examination for fibres and bundles longer than 5 μm in accordance with the procedures described in Annex F. Use a magnification of approximately 10 000 \times for counting of all asbestos fibres and bundles longer than 5 μm , or approximately 5 000 \times if only fibres and bundles within the diameter range 0,2 μm to 3,0 μm are to be counted. Continue the count until completion of the grid opening on which 100 fibres and bundles have been recorded, or until sufficient area of the specimen has been examined to achieve the desired analytical sensitivity. Only those structures which are identified as, or are suspected to be, either chrysotile or one of the amphibole minerals will be reported in either the original or the extended TEM examination. This restriction is intended to ensure that the best statistical validity is obtained for the materials of interest.

TEM ASBESTOS STRUCTURE COUNT

Page of _____

Report Number: _____

Air volume: _____ l

Sample Number: _____

Sample filter area: _____ mm²

Filename: _____

Fraction ashed: _____

Sample description: _____

Dispersal volume: _____ ml

Volume filtered: _____ ml

Analytical filter area: _____ mm²

Preparation date: _____ By: _____

Magnification: _____ ×

Analysis date: _____ By: _____

Grid-opening dimensions: _____ μm

Computer entry date: _____ By: _____

Level of analysis (C): _____

(A): _____

Grid	Grid opening	Structure		Class	Structure	Length mm	Width mm	Comments
		Primary	Total					

Figure 5 — Example of structure-counting form

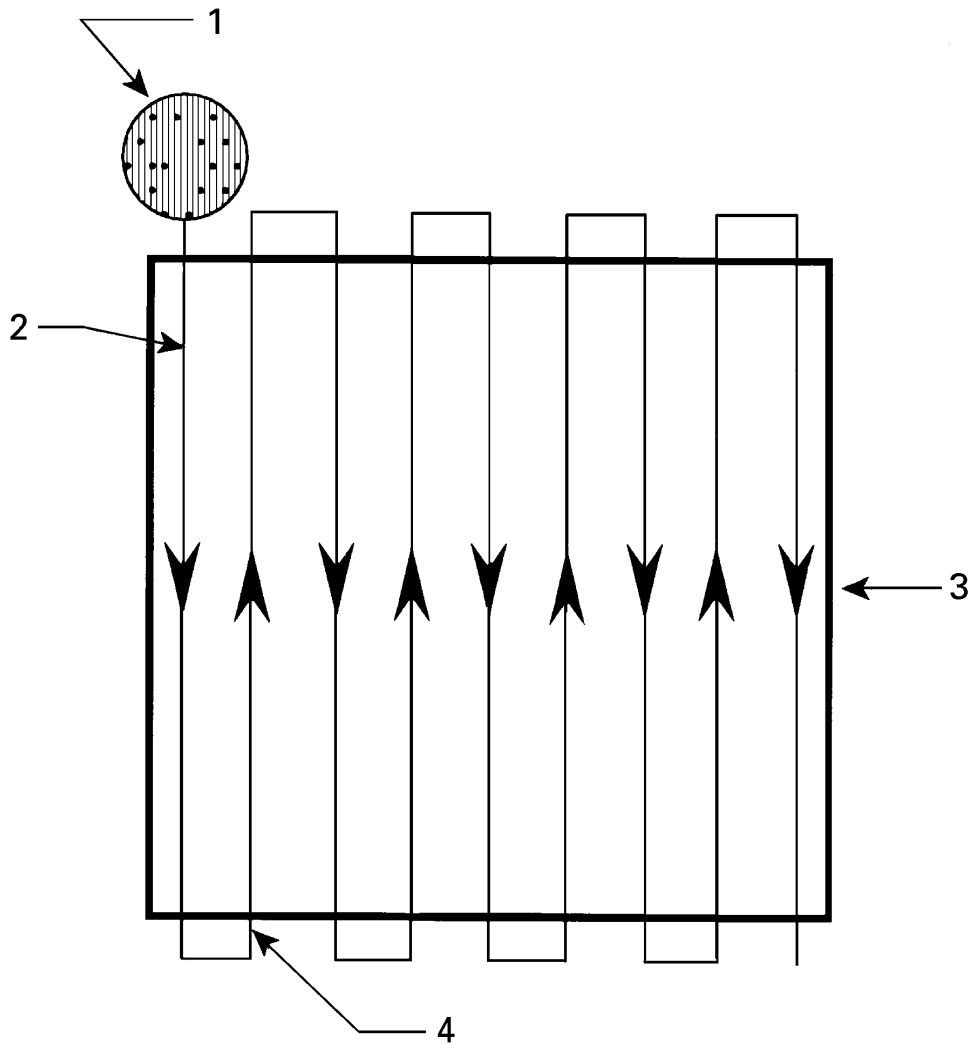

Key

- | | | | |
|---|-------------------|---|--------------|
| 1 | TEM field of view | 3 | Grid opening |
| 2 | First pass | 4 | Second pass |

Figure 6 — Example of scanning procedure for TEM specimen examination

8.7.7 Estimation of mass concentration of asbestos fibres and bundles

If the primary objective of the analysis is to estimate the mass concentration, adopt a structure-counting strategy that allows large structures that contribute most to the mass concentration to be counted with greater statistical reliability. Follow the procedures described in annex D.

8.8 Blank and quality control determinations

Before air samples are collected, analyse a minimum of two unused filters from each lot of 100 filters to determine the mean background asbestos structure count of the analytical procedure. If the mean background count for all types of asbestos structure is found to be more than 10 structures/mm², or if the mean background fibre count for asbestos fibres longer than 5 µm is more than 1,0 fibre/mm², determine the origin of the contamination and correct before air samples are collected.

NOTE The background contamination originating from the sample collection filters is determined by ashing one filter, a group of three filters, and a group of 10 filters. The background contamination originating from a single filter is calculated from any observed incremental increase between these measurements. If a constant background value is obtained for these three measurements, the contamination originates at some other point in the analytical procedure.

Include at least one open field blank and one closed field blank with the samples from each survey. To prepare an open field blank, transport an unused filter cassette to the sampling site and remove the front cap. Locate the open cassette in a similar position and orientation as the samples for the whole period of sample collection, but do not pump air through the filter. After sample collection is completed, replace the front cap and submit the cassette for analysis as the open field blank. To prepare the closed field blank, transport an unused filter cassette to the sampling site and keep it closed.

To ensure that contamination by extraneous asbestos fibres during specimen preparation is insignificant compared with the results reported on samples, establish a continuous programme of blank measurements. Process at least one funnel blank and one empty beaker blank along with each batch of samples. In addition, include at least one unused filter with every group of samples prepared on one microscope slide.

Initially, and also at intervals afterwards, ensure that samples of known asbestos concentrations can be analysed satisfactorily. Since there is a subjective component in the structure-counting procedure, re-counts of some specimens shall be made by different microscopists, in order to minimize the subjective effects. Such re-counts provide a means of maintaining comparability between counts made by different microscopists. Characterize the variability between and within microscopists and between laboratories. These quality assurance measurements shall constitute approximately 10 % of the analyses. Repeat results should not differ at the 5 % significance level.

8.9 Calculation of results

Calculate the results using the procedures detailed in annex G. Prior to TEM examination of the specimens, the level of analysis was specified. Before the results are calculated, specify the compositional and morphological classifications to be included in the result. Conduct the chi-squared uniformity test using the number of primary asbestos structures found on each grid opening, prior to application of the cluster- and matrix-counting criteria. Calculate the concentration result using the numbers of asbestos structures reported after application of the cluster- and matrix-counting criteria.

9 Performance characteristics

9.1 General

It is important to use this analytical method in conjunction with a continuous quality control programme. The quality control programme should include use of standard samples, blank samples, and both inter- and intra-laboratory analyses.

9.2 Interferences and limitations of fibre identification

Unequivocal identification of every chrysotile fibre is not possible, due to both instrumental limitations and the nature of some of the fibres. The requirement for a calibrated ED pattern eliminates the possibility of an incorrect identification of the fibre selected. However, there is a possibility of misidentification of fibres for which both the morphologies and the ED patterns are reported on the basis of visual inspection only. The only significant possibilities of misidentification occur with halloysite, vermiculite scrolls or palygorskite, all of which can be discriminated from chrysotile by the use of EDXA and by observation of the 0,73 nm (002) reflection of chrysotile in the ED pattern.

As in the case of chrysotile fibres, complete identification of every amphibole fibre is not possible due to instrumental limitations and the nature of some of the fibres. Moreover, complete identification of every amphibole fibre is not practical due to the limitations of both time and cost. Particles of a number of other minerals having compositions similar to those of some amphiboles could be erroneously classified as amphibole when the classification criteria do not include zone-axis ED techniques. However, the requirement for quantitative EDXA measurements on all fibres as support for the random orientation ED technique makes misidentification very unlikely, particularly when other similar fibres in the same sample have been identified as amphibole by zone-axis methods. The possibility of misidentification is further reduced with increasing aspect ratio, since it is rare for the minerals with which amphibole may be confused to display an asbestiform habit.

9.3 Precision and accuracy

9.3.1 Precision

The analytical precision that can be obtained is dependent upon the number of structures counted, and also on the uniformity of the particulate deposit on the analytical filter. Assuming that the structures are randomly deposited on the analytical filter, if 100 structures are counted and the loading is at least 3,5 structures/grid opening, computer modelling of the counting procedure shows that a coefficient of variation of about 10 % can be expected. As the number of structures counted decreases, the precision will also decrease approximately as \sqrt{N} , where N is the number of structures counted. In practice, particulate deposits obtained by filtration of aqueous dispersions of particles are rarely ideally distributed, and it is found that the precision is correspondingly reduced. Degradation of precision is a consequence of several factors, such as:

- a) non-uniformity of the filtered particulate deposit;
- b) distortion of the fibre distribution by application of the structure-counting criteria;
- c) variation between microscopists in their interpretation of the fibrous structures; and,
- d) variation between microscopists in their ability to detect and identify fibres.

The 95 % confidence interval about the mean for a single structure-concentration measurement using this analytical method should be approximately ± 25 % when 100 structures are counted over 10 grid openings.

9.3.2 Accuracy

There is no independent method available to determine the accuracy.

NOTE It has been demonstrated that, after carbon-coating of PC membrane filters, particulate material is transferred to the TEM specimens without measurable losses. However, if the filters are heavily loaded with particulate, some material may be lost before they are carbon-coated. Good comparability between the direct-transfer capillary-pore PC procedure and the direct-transfer cellulose ester filter procedure has been demonstrated for laboratory-generated aerosols of chrysotile asbestos collected at a face velocity of 8 cm/s. Using laboratory-generated and field-collected aerosols of chrysotile asbestos, it has been shown that, compared with the direct-transfer procedure, this indirect specimen preparation procedure results in comparable numbers of fibres longer than 5 μm , and less than a factor of two increase in the numbers of fibres longer than 2,5 μm . This indirect specimen preparation procedure may produce results different from those given by the direct-transfer procedure for aerosols of materials in which asbestos is blended with other components.

9.3.3 Inter- and intra-laboratory analyses

Inter- and intra-laboratory analyses are required in order to monitor systematic errors that may develop among microscopists when using this method. These analyses should be designed to test both the overall method and the performance of individual microscopists. Repeat preparation of TEM grids from different sectors of a filter, followed by examination of the grids by a different microscopist, is a test for reproducibility of the whole method. However, non-uniformity of the particulate deposit on the filter may lead to differences which are not related to the performance of the microscopists. Verified fibre-counting (counting of asbestos structures on the same grid opening of a TEM grid by two or more operators, followed by resolution of any discrepancies) may be used both as a training aid and to determine the performance of different microscopists. The use of indexed TEM grids as defined in 5.4.5 and 5.4.6 is recommended in order to facilitate relocation of specific grid openings.

9.4 Limit of detection

The limit of detection of the method can be varied by choice of the volume of air sampled, the proportion of the sample collection filter which is ashed, the proportion of the aqueous dispersion of ash which is filtered, the area of the analytical filter, and the area of the specimen examined in the TEM. It is also a function of the background of asbestos structures on unused filters. A limit of detection shall be quoted for each sample analysis.

NOTE In practice, the lowest limit of detection is frequently determined by the total suspended particulate concentration, since each particle on the analytical filter must be separated from adjacent ones by a sufficient distance that the particle can be identified without interference. Particulate loadings greater than about 25 $\mu\text{g}/\text{cm}^2$ on the analytical filters usually preclude preparation of TEM specimens. If the analysis is to be performed with an acceptable expenditure of time, the area of the specimen examined in the TEM for structures of all sizes is limited in most cases to between 10 and 20 grid openings. In

typical ambient or building atmospheres, it has been found that an analytical sensitivity of 1 structure/litre can be achieved. In some circumstances, where the atmosphere is exceptionally clean, this can be reduced to 0,1 structure/litre or lower. For fibres and bundles longer than 5 µm, the reduced magnifications specified permit larger areas of the TEM specimens to be examined in with an acceptable expenditure of time, resulting in proportionately lower limits of detection. If no structures are found in the analysis, the upper 95 % confidence limit can be quoted as the upper bound of the concentration, corresponding to 2,99 times the analytical sensitivity if a Poisson distribution of structures on the filter is assumed. This 95 % confidence limit for zero structures counted is taken as the detection limit. Since there is sometimes contamination of unused sample filters by asbestos structures, this should also be taken into account in the discussion of limits of detection.

10 Test report

The test report shall include at least items a) to m) as follows:

- a) reference to this International Standard;
- b) identification of the sample;
- c) date and time of sampling, and all necessary sampling data;
- d) date of the analysis;
- e) identity of the analyst;
- f) all necessary specimen preparation data;
- g) any procedure used not specified in this International Standard or regarded as an optional procedure;
- h) statement of the minimum acceptable identification category and the maximum identification category attempted (refer to Tables D.1 and D.2);
- i) statement specifying which identification and structure categories have been used to calculate the concentration values;
- j) the analytical sensitivity, expressed in asbestos structures/litre;
- k) the limit of detection, expressed in asbestos structures/litre;
- l) separate concentration values for chrysotile and amphibole structures, expressed in asbestos structures/litre;
- m) the 95 % confidence interval limits for the concentration values, expressed in asbestos structures/litre.

The following items n) and o) shall be recorded, but their inclusion in the test report is optional:

- n) a complete listing of the structure-counting data. The following data should be included: grid opening number, structure number, identification category, structure type, length and width of the structure expressed in micrometres, and any comments concerning the structure;
- o) compositional data for the principal varieties of amphibole, if present.

Inclusion of the following items p), q) and r) in the test report is optional:

- p) items h) to m) for all asbestos fibres and bundles longer than 5 µm;
- q) items h) to m) for PCM-equivalent asbestos fibres;
- r) estimated mass concentrations of chrysotile and amphibole.

An example of a suitable format for the structure-counting data is shown in Figures 7 and 8.

SAMPLE ANALYSIS INFORMATION

Laboratory name	Report number	Date
SAMPLE: 456 Queen Street Ashby de la Zouch Exterior sample 1991-09-09		
Air volume:	5 750,0 l	
Area of collection filter:	385,0 mm ²	
Volume flowrate:	10,0 l/min	
Fraction of filter ashed:	0,50	
Volume of water used for dispersal of ash:	40,0 ml	
Volume of dispersion filtered:	34,0 ml	
Active area of analytical filter:	199,0 mm ²	
Level of analysis (chrysotile):	CD or CMQ	
Level of analysis (amphibole):	ADQ	
Magnification used for structure counting:	20 500×	
Aspect ratio for fibre definition:	5:1	
Mean dimension of grid openings:	95,4 µm	
Initials of analyst:	JMW	
Number of grid openings examined:	10	
Analytical sensitivity:	0,895 structures/l	
Number of primary asbestos structures:	13	
Number of asbestos structures counted:	26	
Number of asbestos structures > 5 µm:	7	
Number of asbestos fibres and bundles > 5 µm:	10	
Number of PCM-equivalent asbestos structures:	2	
Number of PCM-equivalent asbestos fibres:	5	

Figure 7 — Example of format for reporting of sample and preparation data

SAMPLE ANALYSIS INFORMATION (Page 2 and higher)

Laboratory name

Report number

Date

SAMPLE: 456 Queen Street
Ashby de la Zouch
Exterior sample 1991-09-09

TEM ASBESTOS STRUCTURE COUNT — RAW DATA

Grid	Grid opening	Structures		Identifi- cation ^a	Structure type	Length µm	Width µm	Comments
		Primary	Total					
A	F4-4	1	1	CD	F	1,7	0,045	Crocidolite
		2	2	CMQ	B	3,6	0,09	
		3	3	ADQ	F	4,0	0,15	
	E3-6	4	4	CD	MC+0	3,5	1,3	
		E5-1	5		CD	MD 43	7,5	
	5		5	CD	MB	7,7	0,30	
	6		6	CMQ	MF	5,6	0,045	
	7		7	CD	MB	5,1	0,30	
8	8		CD	MF	1,7	0,045		
B	F4-1	6	6	CD	CD+0	6,5	3,0	
			9	CD	CB	3,5	0,15	
			10	CD	CF	3,5	0,045	
			11	CMQ	CR+0	2,6	1,9	
	G5-1	7	7	CD	CD31	6,1	3,2	
			12	CD	CB	5,6	0,30	
			13	CMQ	CF	4,0	0,045	
	E4-4	8	14	CMQ	CB	3,2	0,090	
			8	15	CD	B	1,5	
9	16	AD	F	8,7	0,15			
C	G4-4	10	10	CMQ	CD42	25,	5,6	Tremolite
			17	CMQ	CB	15,	0,15	
			18	CMQ	CF	9,4	0,045	
			19	ADQ	CF	3,6	0,30	
			20	CM	CF	4,2	0,045	
	E4-4	11	11	No Fibres				
			ADQ	CD+3	9,4	2,5	Amosite Crocidolite	
			21	ADQ	CF	7,1		0,30
	22	ADQ	CF	6,2	0,10			
	E5-6	11	23	CM	CB	5,1	0,20	
			24	CM	CR+0	3,3	1,8	
			25	CMQ	MC10	3,7	2,1	
	F4-1	12	12	25	CMQ	MC10	3,7	2,1
13			26	CD	CC+0	7,4	0,5	

^a Identification codes listed in Tables E.1 and E.2

Figure 8 — Example of format for reporting of structure-counting data

Annex A (normative)

Determination of operating conditions for plasma asher

A.1 General

The plasma asher is used for complete ashing of sample collection filters, and also for an etching procedure during the preparation of TEM specimens from cellulose ester analytical filters.

For complete ashing of either PC or cellulose ester sample collection filters, operate the plasma asher at the minimum power at which a glow discharge can be maintained, until the filter appears to be completely ashed. In order to ensure that the filter has been completely ashed, then operate the plasma asher at full power for longer than 3 h.

During preparation of TEM specimens from a cellulose ester analytical filter, the spongy structure of the filter is collapsed into a thinner film of polymer by action of a solvent. Some of the particles on the surface of the original filter become completely buried in the polymer, and the specimen preparation procedure incorporates a plasma etching step to oxidize the surface layer of the polymer. Particles buried by the filter-collapsing step are then exposed, so that they can become subsequently affixed in the evaporated carbon film without altering their position on the original filter. The amount of etching is critical, and individual ashers vary in performance. Therefore, calibrate the plasma asher to give a known amount of etching of the collapsed-filter surface. This is carried out by adjusting the radio-frequency power output and the oxygen flowrate, and measuring the time taken to completely oxidize an uncollapsed 25 mm diameter cellulose ester filter of the same type and pore size as the analytical filters.

A.2 Procedure

Place an unused, 25 mm diameter MEC or cellulose nitrate filter of the type being used in the centre of a glass microscope slide. Position the slide approximately in the centre of the asher chamber. Close the chamber and evacuate to a pressure of approximately 40 Pa, while admitting oxygen to the chamber at a rate of 8 cm³/min to 20 cm³/min. Adjust the tuning of the system so that the intensity of the plasma is maximized. Measure the time required for complete oxidation of the filter. Determine operating parameters which result in complete oxidation of the filter in a period of approximately 15 min. For etching of collapsed filters, use these operating parameters for a period of 8 min.

NOTE Plasma oxidation at high radio-frequency powers will cause uncollapsed cellulose ester filters to shrink and curl, often followed by sudden violent ignition. At lower powers, the filter will remain in position and will become slowly thinner until it becomes nearly transparent. When multiple filters are etched, the rate of etching is reduced, and the system should be calibrated accordingly.

Annex B (normative)

Determination and standardization of operating conditions for ultrasonic bath

B.1 General

The ultrasonic bath is used for dispersal of the residual ash from sample collection filters. Since prolonged ultrasonic treatment of asbestos dispersions can affect the size distribution of asbestos structures and thereby change the structure concentration, it is important to standardize the rate of ultrasonic energy absorption by the aqueous dispersion and the time for which the sample is exposed to ultrasonic treatment.

Depending on the design of the ultrasonic bath, the rate of energy deposition into the contents of the sample beaker will vary with the position of the sample in the bath and the thickness of the glass. Accordingly, calibrate in the positions used, and always place the sample beakers in these positions. During operation, the temperature of the water in the ultrasonic bath will rise, and will reach an equilibrium temperature. Since energy transfer to the sample beaker increases with the temperature of the water in the bath, operate the bath at its equilibrium temperature.

Ultrasonic energy absorbed by the sample reappears as heat, and the rate of absorption of ultrasonic energy can be measured calorimetrically. Use the measurement procedure specified in B.2.

B.2 Procedure

Ensure that the level of water in the ultrasonic bath is adjusted to that which will be used. Operate the bath until it reaches its equilibrium temperature, accelerating this process if necessary by initially using hot water in the bath. Place 40 ml of water at approximately 20 °C into a 50 ml beaker, and measure its temperature. With the bath switched off, place the beaker into the position to be calibrated. After a period of 60 s to 90 s, remove the beaker and measure the temperature of the contents. Discard the contents of the beaker. Using another 40 ml of water at approximately 20 °C, measure the initial temperature of the contents and, with the ultrasonic bath operating, the final temperature when the beaker has spent the same time in the bath as for the first measurement. Calculate the rate of energy absorption by the sample using the formula:

$$R = 4,185 \times \frac{(\theta_2 - \theta_1)}{t}$$

where

R is the rate of energy absorption, expressed in watts per millilitre (W/ml);

θ_2 is the temperature rise with ultrasonic bath operating, expressed in degrees Celsius (°C);

θ_1 is the temperature rise with ultrasonic bath not operating, expressed in degrees Celsius (°C);

t is the time, expressed in seconds (s).

If the rate of energy absorption is higher than the specified range, use a variable transformer as the power supply for the ultrasonic bath, and adjust the operating conditions so that the rate of energy absorption is in the range 0,05 W/ml to 0,1 W/ml, as defined by this measurement procedure.

Always operate the ultrasonic bath at its equilibrium temperature, because the energy transfer to the beaker increases with temperature. If a thermometer is used for temperature measurement when calibrating the bath, do

not immerse the thermometer in the beaker of water during the exposure to the bath, because the presence of the thermometer increases the absorption of energy during ultrasonic treatment. Alternatively, a low thermal capacity thermocouple may be used for temperature measurement.

Annex C (normative)

Calibration procedures

C.1 Calibration of the TEM

C.1.1 Calibration of TEM screen magnification

The electron microscope should be aligned according to the specifications of the manufacturer. Initially, and at regular intervals, calibrate the magnifications used for the analysis using a diffraction grating replica. Adjust the specimen height to the eucentric position before carrying out the calibration. On the fluorescent viewing screen, measure the distance occupied by a convenient number of repeat distances of the grating image, and calculate the magnification. Always repeat the calibration after any instrumental maintenance or change in operating conditions. The magnification of the image on the viewing screen is not the same as that obtained on photographic plates or film. The ratio between these is a constant value for the particular model of TEM.

C.1.2 Calibration of ED camera constant

Calibrate the camera constant of the TEM when used in ED mode. Use a specimen grid supporting a carbon film on which a thin film of gold has been evaporated or sputtered. Form an image of the gold film with the specimen adjusted to the eucentric position and select ED conditions. Adjust the objective-lens current to optimize the pattern obtained, and measure either on the fluorescent viewing screen or on a recorded image the diameters of the innermost two rings. Calculate the radius-based camera constant, $\lambda \cdot L$, for both the fluorescent screen and the photographic plate or film, from the relationship:

$$\lambda \cdot L = \frac{a \cdot D}{2,0 \sqrt{h^2 + k^2 + l^2}}$$

where

λ is the wavelength of the incident electrons, expressed in nanometres (nm);

L is the camera length, expressed in millimetres (mm);

a is the unit cell dimension of gold, expressed in nanometres (0,40786 nm);

D is the diameter of the (hkl) diffraction ring, expressed in millimetres (mm).

Using gold as the calibration material, the radius-based camera constant is given by:

$$\lambda \cdot L = 0,11774D \text{ mm} \cdot \text{nm} \text{ (smallest ring);}$$

$$\lambda \cdot L = 0,10197D \text{ mm} \cdot \text{nm} \text{ (second ring).}$$

C.1.3 Calibration of the EDXA system

Perform energy calibration of the EDXA system for a low-energy and a high-energy peak regularly. Calibration of the intensity scale of the EDXA system permits quantitative composition data, at an accuracy of about 10 % of the elemental concentration, to be obtained from EDXA spectra of reference silicate minerals containing the elements Na, Mg, Al, Si, K, Ca, Mn and Fe, and relevant certified reference materials. If quantitative determinations are required for minerals containing other elements, reference standards other than those referred to below will be required. Well-characterized mineral standards permit calibration of any TEM-EDXA combination which meets the

instrumental specifications of 5.3.1 and 5.3.2, so that EDXA data from different instruments can be compared. Reference minerals are required for the calibration; the criteria for selection being that they should be silicate minerals with matrices as close as possible to those of the amphiboles or serpentine, and that individual small fragments of the minerals are homogeneous in composition within a few percent.

Determine the compositions of these standards by electron microprobe analysis or chemical methods. Crush fragments of the same selected mineral standards and prepare filters by dispersal of the crushed material in water and immediate filtration of the suspensions. Prepare TEM specimens from these filters by the procedures described in clause 8. These TEM specimens can then be used to calibrate any TEM-EDXA system so that comparable compositional results can be obtained from different instruments.

NOTE The microprobe analyses of the mineral standards are made by conventional techniques which can be found in the Bibliography. In summary, the mineral is first embedded in a mount of polymethyl methacrylate or epoxy resin. The mount is then ground and polished to achieve a flat, polished surface of the mineral fragment. This surface is then analyzed, using suitable reference standards, preferably oxide standards of the individual elements wherever these are available. It is necessary to take account of the water concentration in the minerals, which in the case of chrysotile amounts to 13 % by mass. This water content may vary due to losses in the vacuum system.

Aqueous suspensions of mineral standards should be filtered immediately after preparation, since alkali and alkaline earth metals may be partially leached from minerals containing these elements.

Express the results of the electron microprobe analyses as atomic or mass percentage ratios relative to silicon. X-ray peak ratios of the same elements relative to silicon, obtained from the EDXA system, can then be used to calculate the relationship between peak area ratio and atomic or mass percentage ratio. This technique is described by Cliff and Lorimer (see Bibliography).

The X-rays generated in a thin specimen by an incident electron beam have a low probability of interacting with the specimen. Thus mass absorption and fluorescence effects are negligible. In a silicate mineral specimen containing element i , the following relationship can be used to perform quantitative analyses in the TEM.

$$\frac{C_i}{C_{Si}} = k_i \cdot \frac{A_i}{A_{Si}}$$

where

C_i is the concentration or atomic proportion of element i ;

C_{Si} is the concentration or atomic proportion of silicon;

A_i is the elemental integrated peak area for element i ;

A_{Si} is the elemental integrated peak area for silicon;

k_i is the k -ratio for element i relative to silicon (a constant).

NOTE For a particular instrumental configuration and a particular particle size, the value of k_i is constant.

To incorporate correction for the particle-size effect on peak area ratios (see Small *et al.* in Bibliography), extend the Cliff and Lorimer technique by obtaining separate values of the constant k_i for different ranges of fibre diameter. It is recommended that 20 EDXA measurements be made for each range of fibre diameter. Suitable ranges of fibre diameter are $< 0,25 \mu\text{m}$; $0,25 \mu\text{m}$ to $0,5 \mu\text{m}$; $0,5 \mu\text{m}$ to $1,0 \mu\text{m}$ and $> 1,0 \mu\text{m}$.

Insert the TEM grid into the TEM, obtain an image at the calibrated higher magnification of about $20\,000\times$, and adjust the specimen height to the eucentric point. If the X-ray detector is a side-entry variety, tilt the specimen towards the X-ray detector. Select an isolated fibre or particle less than $0,5 \mu\text{m}$ in width, and accumulate an EDXA spectrum using an electron probe of suitable diameter. When a well-defined spectrum has been obtained, perform a background subtraction and calculate the background-corrected peak areas for each element listed, using energy windows centred on the peaks. Calculate the ratio of the peak area for each specified element relative to the peak area for silicon. All background-subtracted peak areas used for calibration shall exceed 400 counts.

Repeat this procedure for 20 particles of each mineral standard. Reject analyses of any obviously foreign particles. Calculate the arithmetic mean concentration to peak area ratio, k_i (k -ratio), for each specified element of each mineral standard and for each of the fibre diameter ranges. Periodic routine checks shall be carried out to ensure that there has been no degradation of the detector performance. These k -ratios are used to calculate the elemental concentrations of unknown fibres, using the Cliff and Lorimer relationship.

Annex D (normative)

Structure-counting criteria

D.1 Introduction

In addition to isolated fibres, assemblages of particles and fibres frequently occur in air samples. Groupings of asbestos fibres and particles, referred to as "asbestos structures", are defined as fibre bundles, clusters and matrices. The numerical result of a TEM examination depends strongly on whether the analyst assigns such an assemblage of fibres as a single entity, or as the estimated number of individual fibres which form the assemblage. It is therefore important that a logical system of counting criteria be defined, so that the interpretation of these complex structures is the same for all analysts, and so that the numerical result is meaningful. Imposition of specific structure-counting criteria generally requires that some interpretation, partially based on uncertain health effects information, be made of each asbestos structure found. It is not the intention of this International Standard to make any interpretations based on health effects, and it is intended that a clear separation be made between recording of structure-counting data, and later interpretation of those data. The system of coding specified in this International Standard permits a clear morphological description of the structures to be recorded in a concise manner suitable for later interpretation, if necessary, by a range of different criteria, without the necessity for re-examination of the specimens. In particular, the coding system is designed to permit recording of the dimensions of each complex fibrous structure, and also whether these structures contain fibres longer than 5 µm. This approach permits later evaluations of the data to include considerations of particle respirability and comparisons with historical indices of asbestos exposure. Examples of the various types of morphological structure, and the manner in which these shall be recorded, are shown in Figure D.1.

D.2 Structure definitions and treatment

Each fibrous structure that is a separate entity shall be designated as a primary structure. Each primary structure shall be designated as a fibre, bundle, cluster or matrix. These structures are discussed in D.2.1 to D.2.8.

D.2.1 Fibre

Any particle with parallel or stepped sides, of minimum length 0,5 µm, and with an aspect ratio of 5:1 or greater, shall be defined as a fibre. For chrysotile asbestos, the single fibril shall be defined as a fibre. A fibre with stepped sides shall be assigned a width equal to the average of the minimum and maximum widths. This average shall be used as the width in determination of the aspect ratio.

D.2.2 Bundle

A grouping composed of apparently attached parallel fibres shall be defined as a bundle, with a width equal to an estimate of the mean bundle width, and a length equal to the maximum length of the structure. The overall aspect ratio of the bundle may be any value, provided that it contains individual constituent fibres having aspect ratios equal to or greater than 5:1. Bundles may exhibit diverging fibres at one or both ends.

D.2.3 Cluster

An aggregate of two or more randomly oriented fibres, with or without bundles, shall be defined as a cluster. Clusters occur as two varieties:

- a) disperse cluster (type D): a disperse and open network, in which at least one of the individual fibres or bundles can be separately identified and its dimensions measured;
- b) compact cluster (type C): a complex and tightly bound network, in which one or both ends of each individual fibre or bundle are obscured, such that the dimensions of individual fibres and bundles cannot be unambiguously determined.

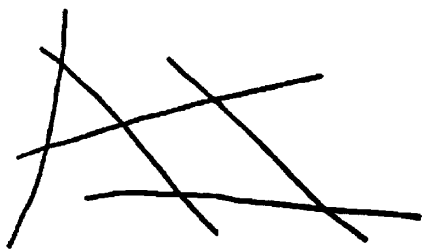
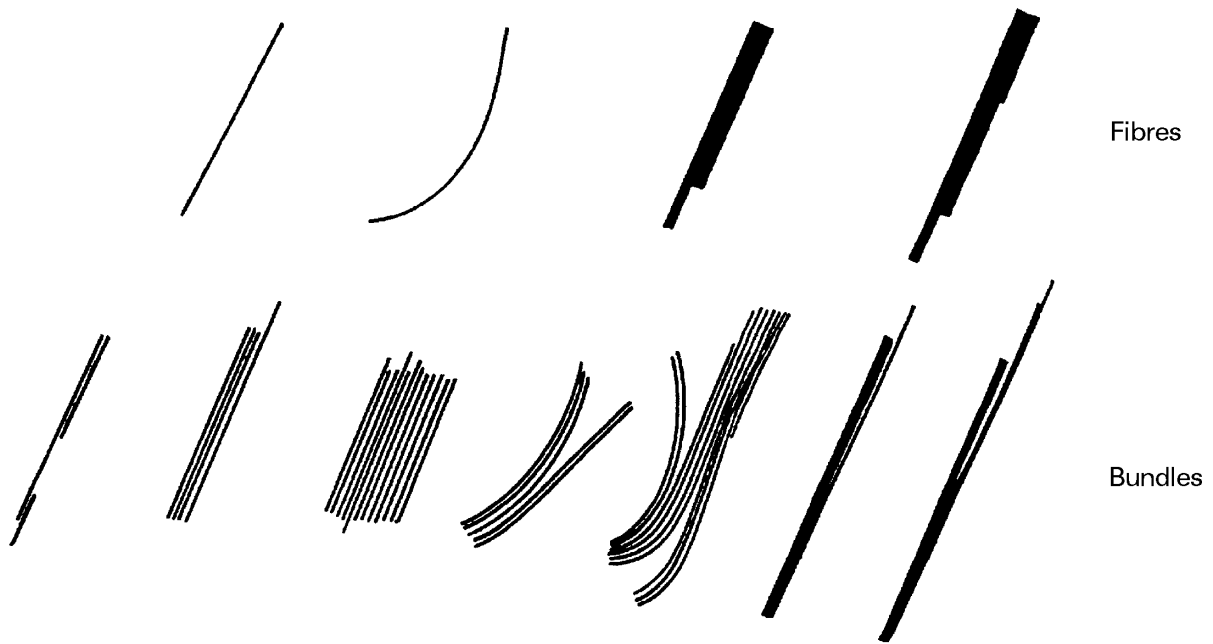

Disperse cluster (type D)



Compact cluster (type C)

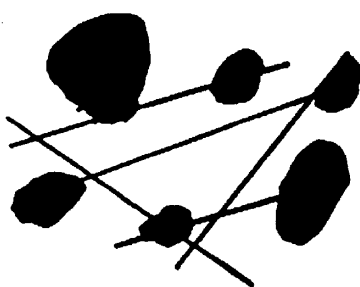

Disperse matrix (type D)

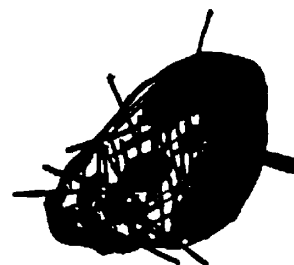

Compact matrix (type C)

Figure D.1 — Fundamental morphological structure types

In practice, clusters can occur in which the characteristics of both types of cluster occur in the same structure. Where this occurs, the structure should be assigned as a disperse cluster, and then a logical procedure should be followed by recording structure components according to the counting criteria. The procedure for treatment of clusters is illustrated by examples in Figure D.2.

D.2.4 Matrix

One or more fibres, or fibre bundles, may be attached to, or partially concealed by, a single particle or group of overlapping non-fibrous particles. This structure shall be defined as a matrix. The TEM image does not discriminate between particles which are attached to fibres and those which have by chance overlapped in the TEM image. It is not known, therefore, whether such a structure is actually a complex particle, or whether it has arisen by a simple overlapping of particles and fibres on the filter.

Since a matrix structure may involve more than one fibre, it is important to define in detail how matrices shall be counted. Matrices exhibit different characteristics, and two types can be defined:

- a) disperse matrix (type D): a structure consisting of a particle or linked group of particles, with overlapping or attached fibres or bundles in which at least one of the individual fibres or bundles can be separately identified and its dimensions measured;
- b) compact matrix (type C): a structure consisting of a particle or linked group of particles, in which fibres or bundles can be seen either within the structure or projecting from it, such that the dimensions of individual fibres and bundles cannot be unambiguously determined.

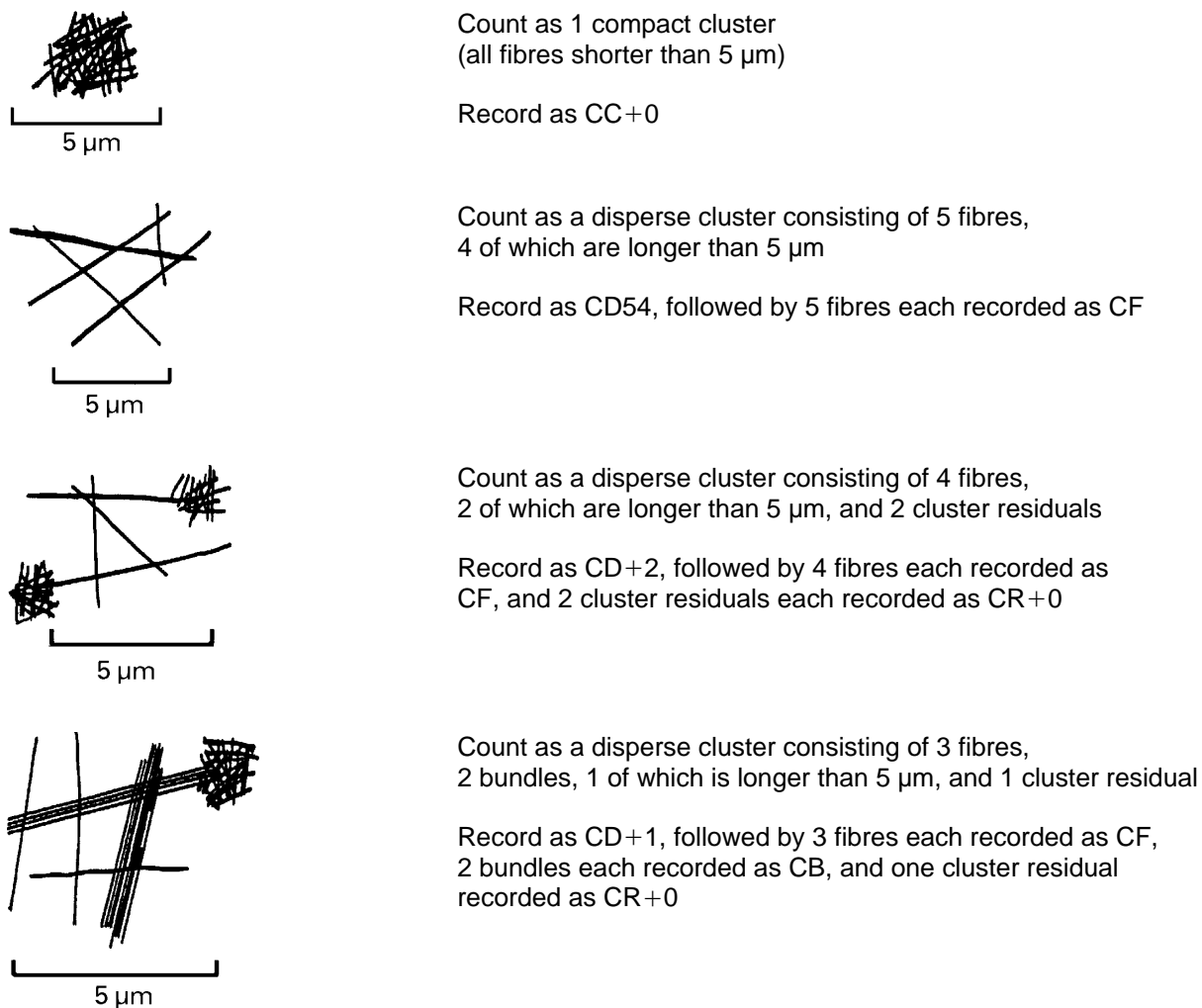

Figure D.2 — Examples of recording of complex asbestos clusters

Licensed to IATL/JOHN NAPOLITAN
 ISO Store order #:852310/Downloaded:2007-10-04
 Single user licence only, copying and networking prohibited

In practice, matrices can occur in which the characteristics of both types of matrix occur in the same structure. Where this occurs, the structure should be assigned as a disperse matrix, and then a logical procedure should be followed by recording structure components according to the counting criteria. Examples of the procedure which shall be followed are shown in Figure D.3.

D.2.5 Asbestos structure larger than 5 mm

Any fibre, bundle, cluster or matrix for which the largest dimension exceeds 5 µm. Asbestos structures larger than 5 µm do not necessarily contain asbestos fibres or bundles longer than 5 µm.

D.2.6 Asbestos fibre or bundle longer than 5 mm

An asbestos fibre of any width, or bundle of such fibres, which has a length exceeding 5 µm.

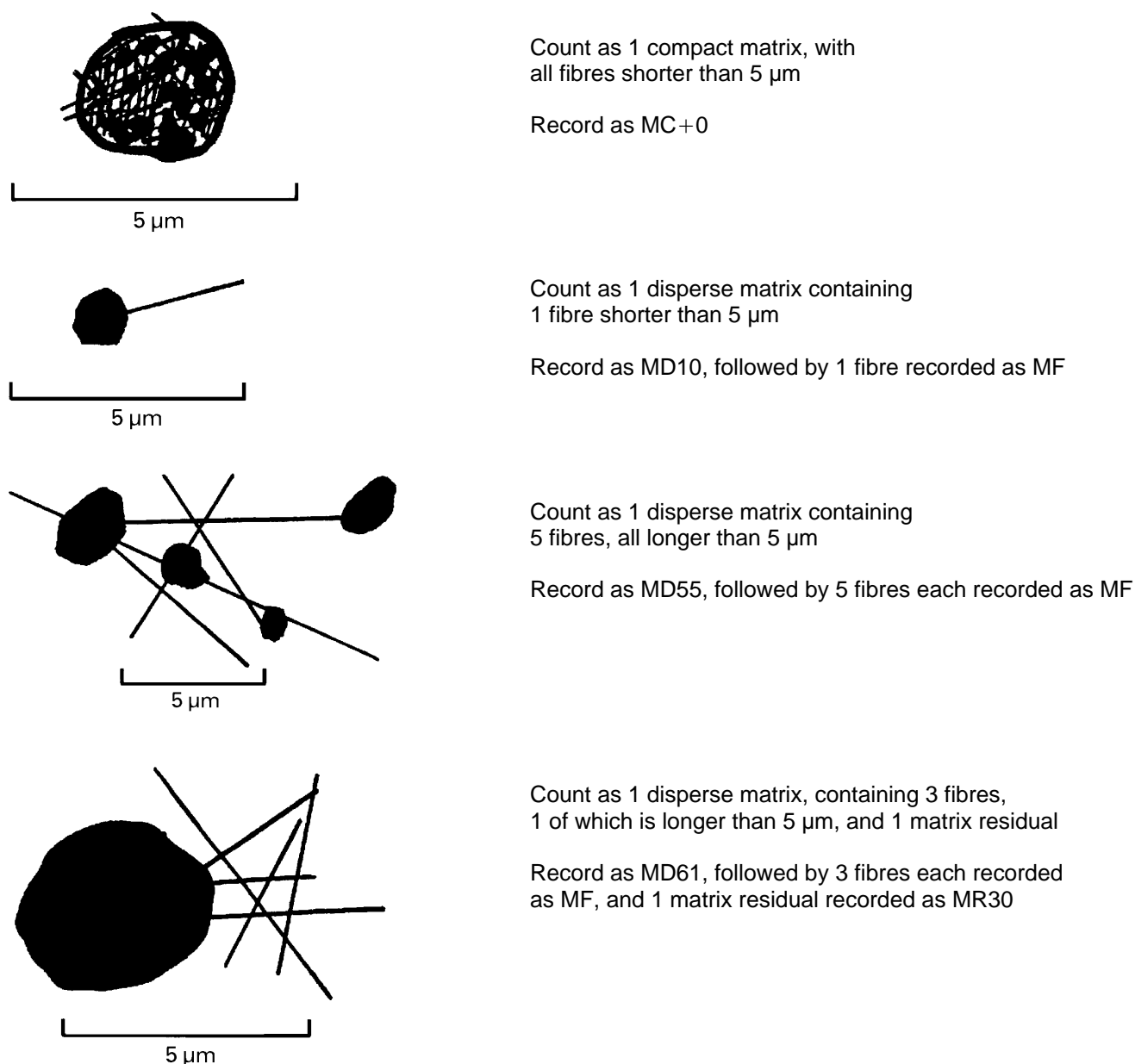

Figure D.3 — Examples of recording of complex asbestos matrices

D.2.7 PCM-equivalent structure

Any fibre, bundle, cluster or matrix with an aspect ratio of 3:1 or greater, longer than 5 µm, and which has a diameter between 0,2 µm and 3,0 µm. PCM-equivalent structures do not necessarily contain fibres or bundles longer than 5 µm, or PCM-equivalent fibres.

D.2.8 PCM-equivalent fibre

Any particle with parallel or stepped sides, with an aspect ratio of 3:1 or greater, longer than 5 µm, and which has a diameter between 0,2 µm and 3,0 µm. For chrysotile, PCM-equivalent fibres will always be bundles.

D.3 Other structure-counting criteria

D.3.1 Structures which intersect grid bars

Count a structure which intersects a grid bar for two sides of the grid opening only, as illustrated in Figure D.4. Record the dimensions of the structure such that the obscured portions of components are taken to be equivalent to the unobscured portions, as shown by the broken lines in Figure D.4. For example, the length of a fibre intersecting a grid bar is taken to be twice the unobscured length. Structures intersecting either of the other two sides shall not be included in the count.

D.3.2 Fibres which extend outside the field of view

During scanning of a grid opening, count fibres which extend outside the field of view systematically, so as to avoid double-counting. In general, a rule should be established so that fibres extending outside the field of view in only two quadrants are counted. The procedure is illustrated by Figure D.5. Measure the length of each such fibre by moving the specimen to locate the other end of the fibre, and then return to the original field of view before continuing to scan the specimen. Fibres without terminations within the field of view shall not be counted.

D.4 Procedure for data recording

D.4.1 Introduction

The morphological codes specified are designed to facilitate computer data-processing, and to allow recording of a complete representation of the important features of each asbestos structure. The procedure requires that the microscopist classify each primary fibrous structure into one of the four fundamental categories: fibres, bundles, clusters and matrices.

D.4.2 Fibres

On the structure-counting form, a fibre as defined in D.2.1 shall be recorded by the designation "F". If the fibre is a separately-counted part of a cluster or matrix, the fibre shall be recorded by the designation "CF", or "MF", depending on whether it is a component of a cluster or matrix.

D.4.3 Bundles

On the structure-counting form, a bundle as defined in D.2.2 shall be recorded by the designation "B". If the bundle is a separately-counted part of a cluster or matrix, the bundle shall be recorded by the designation "CB", or "MB", depending on whether it is a component of a cluster or matrix.

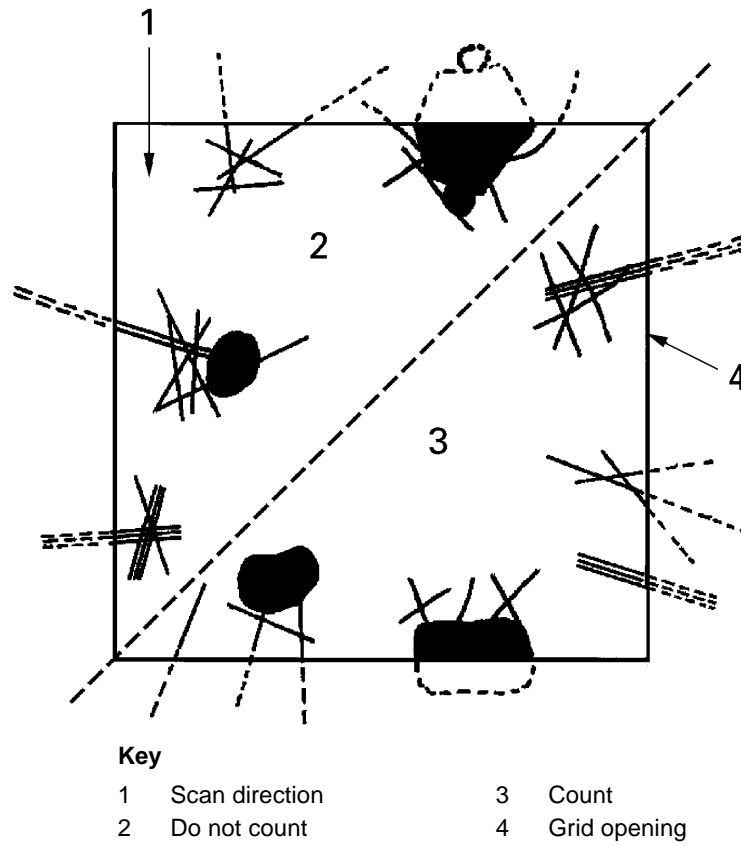

Figure D.4 — Example of counting of structures which intersect grid bars

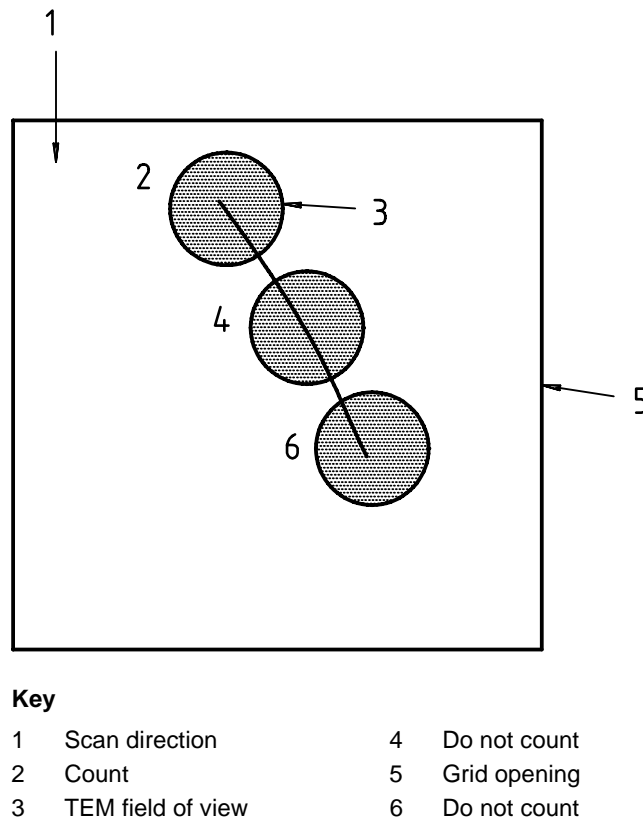

Figure D.5 — Example of counting of fibres which extend outside the field of view

D.4.4 Disperse clusters (type D)

On the structure-counting form, an isolated cluster of type D as defined in D.2.3 shall be recorded by the designation "CD", followed by a two-digit number. The first digit represents the analyst's estimate of the total number of fibres and bundles comprising the structure. The digit shall be from 1 to 9, or designated as "+" if there are estimated to be more than 9 component fibres or bundles. The second digit shall represent, in the same manner, the total number of fibres and bundles longer than 5 µm contained in the structure. The overall dimensions of the cluster in two perpendicular directions representing the maximum dimensions shall be recorded. In order of decreasing length, up to five component fibres or bundles shall be separately recorded, using the codes "CF" (cluster fibre) and "CB" (cluster bundle). If, after accounting for prominent component fibres and bundles, a group of clustered fibres remains, this shall be recorded as "CR" (cluster residual). If the remaining clustered fibres are present as more than one localized group, it may be necessary to record more than one cluster residual. Do not record more than five cluster residuals for any cluster. A cluster residual shall be measured and assigned a two-digit number, derived in the same manner as specified for the overall cluster. Optionally, if the number of component fibres and bundles in either the original cluster or the cluster residual is outside of the range of 1 to 9, additional information concerning the number of component fibres and bundles may be noted in the "comments" column.

D.4.5 Compact clusters (type C)

On the structure-counting form, an isolated cluster of type C as defined in D.2.3 shall be recorded by the designation "CC", followed by a two-digit number. The two-digit number describing the numbers of component fibres and bundles shall be assigned in the same manner as for clusters type D. The overall dimensions of the cluster in two perpendicular directions shall be recorded in the same manner as for clusters type D. By definition, the constituent fibres and bundles of compact clusters cannot be separately measured, therefore no separate tabulation of component fibres or bundles can be made.

D.4.6 Disperse matrices (type D)

On the structure counting form, an isolated matrix of type D as defined in D.2.4 shall be recorded by the designation "MD", followed by a two-digit number. The two digit number shall be assigned in the same manner as for clusters type D. The overall dimensions of the matrix in two perpendicular directions shall be recorded in the same manner as for clusters type D. In order of decreasing length, up to five component fibres or bundles shall be separately recorded, using the codes "MF" (matrix fibre) and "MB" (matrix bundle). If, after accounting for prominent component fibres and bundles, matrix material containing asbestos fibres remains, this shall be recorded as "MR" (matrix residual). If the remaining matrix fibres are present as more than one localized group, it may be necessary to record more than one matrix residual. Do not record more than five matrix residuals for any matrix. A matrix residual shall be measured and assigned a two-digit number, derived in the same manner as specified for the overall matrix. Optionally, if the number of component fibres and bundles in either the original matrix or the matrix residual is outside of the range of 1 to 9, additional information concerning the number of component fibres and bundles may be noted in the "comments" column.

D.4.7 Compact matrices (type C)

On the structure counting form, an isolated matrix of type C as defined in D.2.4 shall be recorded by the designation "MC", followed by a two-digit number. The two-digit number shall be assigned in the same manner as for clusters type D. The overall dimensions of the matrix in two perpendicular directions shall be recorded in the same manner as for clusters type D. By definition, the constituent fibres and bundles of compact matrices cannot be separately measured, therefore no separate tabulation of component fibres or bundles can be made.

D.4.8 Procedure for recording partially obscured fibres and bundles

The proportion of the length of a fibre or bundle that is obscured by other particulates shall be used as the basis for determining whether a fibre or bundle is to be recorded as a separate component or is to be considered a part of a matrix type C or a part of a matrix residual. If the obscured length could not possibly be more than one-third of the total length, the fibre or bundle shall be considered a prominent feature to be separately recorded. The assigned length for each such partially-obscured fibre or bundle shall be equal to the visible length plus the maximum possible contribution from the obscured portion. Fibres or bundles which appear to cross the matrix, and for which both ends can be located approximately, shall be included in the maximum count of five and recorded according to the counting criteria as separate fibres or bundles. If the obscured length could be more than one-third of the total length, the fibre or bundle shall be considered as a part of a compact matrix type C or part of a matrix residual.

D.5 Special considerations for counting PCM-equivalent structures

Use 3:1 as the minimum aspect ratio for counting PCM-equivalent structures. This aspect ratio definition is required in order to achieve comparability of the results for this size range of structure with historical optical measurements, but use of this aspect ratio definition does not significantly affect the ability to interpret the whole fibre size distribution in terms of a minimum 5:1 aspect ratio. Some applications may require that a count be made of PCM-equivalent structures only. The coding system permits discrimination between PCM-equivalent structures that contain fibres and bundles longer than 5 µm and those that do not.

NOTE In general, clusters and matrices will yield fewer components as the minimum dimensions specified for countable fibres are increased. Thus it may be found that a particular structure yields a higher number of component fibres in a count for all fibre sizes than it does at a reduced magnification when only fibres and bundles longer than 5 µm are being counted. However, the requirement that component fibres and bundles be recorded in order of decreasing length ensures that the data are consistent for a particular structure, regardless of the size category of fibres being counted and the magnification in use.

D.6 Special considerations for estimation of the mass concentration of asbestos fibres and bundles

If the primary objective of the analysis is to estimate the mass concentration, it is necessary to adopt a structure-counting strategy that allows large structures that contribute most to the mass concentration to be counted with greater statistical reliability. The number of structures that must be counted in order to achieve a reliable estimate of the mass concentration depends primarily on the range of diameter distribution. The mass concentration measurement is most sensitive to fibres and bundles of large diameters, which are generally statistically infrequent relative to the smaller fibres and bundles. If the diameter distribution is narrow, such as that found in a dispersion of chrysotile fibrils, the mass concentration can be measured with approximately the same precision as that of the numerical concentration. If the diameter distribution is broad, mass concentration estimates derived from TEM examinations to determine numerical concentrations are statistically unreliable. The strategy specified below is designed to give greater statistical significance to the large structures, which contribute most to the mass concentration.

Initially, establish the largest width of asbestos fibre or bundle that can be detected on the grid by a cursory survey, at a reduced magnification, of approximately 50 grid openings. Calculate the volume of this structure. Adjust the magnification of the TEM to a value such that a width of 1 mm on the fluorescent screen corresponds to approximately 10 % of the width of the previously-selected large structure. Carry out a routine TEM examination at this magnification, terminating the examination at the end of the grid opening on which the integrated volume of all structures recorded is at least 10 times the volume of the originally-selected structure. For asbestos structures which intercept the grid bars, measure only the unobscured parts of the fibres and bundles within the grid opening, for the purposes of calculation of the mass concentration of asbestos. Disregard the procedure indicated in D.3.1 and Figure D.4.

Annex E (normative)

Fibre identification procedure

E.1 Introduction

The criteria used for identification of asbestos fibres may be selected as a function of the intended use of the measurements. In some circumstances, there can be a requirement that fibres shall be unequivocally identified as a specific mineral species. In other circumstances there can be sufficient knowledge about the sample that rigorous identification of each fibre need not be carried out. The time required to perform the analysis, and therefore the cost of analysis, can vary widely depending on the identification criteria which are considered to be sufficiently definitive. The combination of criteria considered definitive for identification of fibres in a particular analysis shall be specified before the analysis is made, and this combination of criteria shall be referred to as the "Level" of analysis. Various factors related to instrumental limitations and the character of the sample may prevent satisfaction of all of the specified fibre identification criteria for a particular fibre. Therefore, a record shall be made of the identification criteria which were satisfied for each suspected asbestos fibre included in the analysis. For example, if both ED and EDXA were specified to be attempted for definitive identification of each fibre, fibres with chrysotile morphology which, for some reason, do not give an ED pattern but which do yield an EDXA spectrum corresponding to chrysotile, are categorized in a way which conveys the level of confidence to be placed in the identification.

E.2 ED and EDXA techniques

E.2.1 General

Initially, classify fibres into two categories on the basis of morphology: those fibres with tubular morphology, and those fibres without tubular morphology. Conduct further analysis of each fibre using ED and EDXA methods. The following procedures should be used when fibres are examined by ED and EDXA.

The crystal structures of some mineral fibres, such as chrysotile, are easily damaged by the high current densities required for EDXA examination. Therefore, investigation of these sensitive fibres by ED shall be completed before attempts are made to obtain EDXA spectra from the fibres. When more stable fibres, such as the amphiboles, are examined, EDXA and ED may be used in either order.

E.2.2 ED techniques

The ED technique can be either qualitative or quantitative. Qualitative ED consists of visual examination, without detailed measurement, of the general characteristics of the ED pattern obtained on the TEM viewing screen from a randomly oriented fibre. ED patterns obtained from fibres with cylindrical symmetry, such as chrysotile, do not change when the fibres are tilted about their axes, and patterns from randomly oriented fibres of these minerals can be interpreted quantitatively. For fibres which do not have cylindrical symmetry, only those ED patterns obtained when the fibre is oriented with a principal crystallographic axis closely parallel with the incident electron-beam direction can be interpreted quantitatively. This type of ED pattern shall be referred to as a zone-axis ED pattern. In order to interpret a zone-axis ED pattern quantitatively, it shall be recorded photographically and its consistency with known mineral structures shall be checked. A computer program may be used to compare measurements of the zone-axis ED pattern with corresponding data calculated from known mineral structures. The zone-axis ED pattern obtained by examination of a fibre in a particular orientation can be insufficiently specific to permit unequivocal identification of the mineral fibre, but it is often possible to tilt the fibre to another angle and to record a different ED pattern corresponding to another zone-axis. The angle between the two zone-axes can also be checked for consistency with the structure of a suspected mineral.

For visual examination of the ED pattern, the camera length of the TEM should be set to a low value of approximately 250 mm and the ED pattern then should be viewed through the binoculars. This procedure minimizes

the possible degradation of the fibre by the electron irradiation. However, the pattern is distorted by the tilt angle of the viewing screen. A camera length of at least 2 m should be used when the ED pattern is recorded, if accurate measurement of the pattern is to be possible. It is necessary that, when obtaining an ED pattern to be evaluated visually or to be recorded, the sample height shall be properly adjusted to the eucentric point and the image shall be focussed in the plane of the selected area aperture. If this is not done there may be some components of the ED pattern which do not originate from the selected area. In general, it is necessary to use the smallest available ED aperture.

For accurate measurements of the ED pattern, an internal calibration standard shall be used. Apply a thin coating of gold, or other suitable calibration material, to the underside of the TEM specimen. This coating may be applied either by vacuum evaporation or, more conveniently, by sputtering. The polycrystalline gold film yields diffraction rings on every ED pattern and these rings provide the required calibration information.

To form an ED pattern, move the image of the fibre to the centre of the viewing screen, adjust the height of the specimen to the eucentric position, and insert a suitable selected area aperture into the electron beam so that the fibre, or a portion of it, occupies a large proportion of the illuminated area. The size of the aperture and the portion of the fibre shall be such that particles other than the one to be examined are excluded from the selected area. Observe the ED pattern through the binoculars. During the observation, the objective lens current should be adjusted to the point where the most complete ED pattern is obtained. If an incomplete ED pattern is still obtained, move the particle around within the selected area to attempt to optimize the ED pattern, or to eliminate possible interferences from neighbouring particles.

If a zone-axis ED analysis is to be attempted on the fibre, the sample shall be mounted in the appropriate holder. The most convenient holder allows complete rotation of the specimen grid and tilting of the grid about a single axis. Rotate the sample until the fibre image indicates that the fibre is oriented with its length coincident with the tilt axis of the goniometer, and adjust the sample height until the fibre is at the eucentric position. Tilt the fibre until an ED appears which is a symmetrical, two dimensional array of spots. The recognition of zone-axis alignment conditions requires some experience on the part of the operator. During tilting of the fibre to obtain zone-axis conditions, the manner in which the intensities of the spots vary should be observed. If weak reflections occur at some points on a matrix of strong reflections, the possibility of twinning or multiple diffraction exists, and some caution should be exercised in the selection of diffraction spots for measurement and interpretation. A full discussion of electron diffraction and multiple diffraction can be found in the references by Gard, Hirsch *et al.*, and Wenk in the Bibliography. Not all zone-axis patterns which can be obtained are definitive. Only those which have closely-spaced reflections corresponding to low indices in at least one direction should be recorded. Patterns in which all d -spacings are less than about 0,3 nm are not definitive. A useful guideline is that the lowest angle reflections should be within the radius of the first gold diffraction ring (111), and that patterns with smaller distances between reflections are usually the most definitive.

Five spots, closest to the centre spot, along two intersecting lines of the zone-axis pattern shall be selected for measurement, as illustrated in Figure E.1. The distances of these spots from the centre spot and the four angles shown provide the required data for analysis. Since the centre spot is usually very over-exposed, it does not provide a well-defined origin for these measurements. The required distances shall therefore be obtained by measuring between pairs of spots symmetrically disposed about the centre spot, preferably separated by several repeat distances. The distances must be measured with a precision of better than 0,3 mm, and the angles to a precision of better than 2,5°. The diameter of the first or second ring of the calibration pattern (111 and 200) must also be measured with a precision of better than 0,3 mm.

Using gold as the calibration material, the radius-based camera constant is given by:

$$\lambda \cdot L = 0,11774D \text{ mm} \cdot \text{nm} \text{ (first ring)}$$

$$\lambda \cdot L = 0,10197D \text{ mm} \cdot \text{nm} \text{ (second ring)}$$

E.2.3 EDXA measurements

Interpretation of the EDXA spectrum may be either qualitative or quantitative. For qualitative interpretation of a spectrum, the X-ray peaks originating from the elements in the fibre are recorded. For quantitative interpretation, the net peak areas, after background subtraction, are obtained for the X-ray peaks originating from the elements in the fibre. This method provides quantitative interpretation for those minerals which contain silicon.

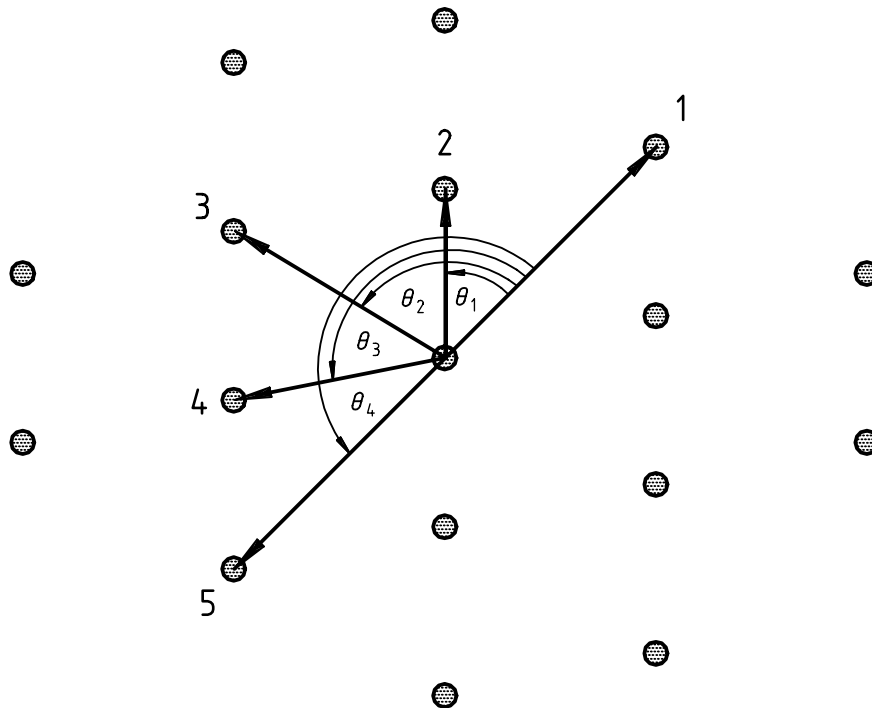

Figure E.1 — Example of measurement of five spots in zone-axis SAED patterns

To obtain an EDXA spectrum, move the image of the fibre to the centre of the screen and remove the objective aperture. Select an appropriate electron beam diameter and deflect the beam so that it impinges on the fibre. Depending on the instrumentation, it may be necessary to tilt the specimen towards the X-ray detector and, in some instruments, to use a scanning transmission electron microscopy (STEM) mode of operation.

The time for acquisition of a suitable spectrum varies with the fibre diameter, and also with instrumental factors. For quantitative interpretation, spectra should have a statistically valid number of counts in each peak. Analyses of small-diameter fibres which contain sodium are the most critical, since it is in the low energy range that the X-ray detector is least sensitive. Accordingly, it is necessary to acquire a spectrum over a sufficiently long period that the presence of sodium can be detected in such fibres. It has been found that satisfactory quantitative analyses can be obtained if acquisition is continued until the background-subtracted silicon $K\alpha$ peak integral exceeds 10 000 counts. The spectrum should then be manipulated to subtract the background and to obtain the net areas of the elemental peaks.

After quantitative EDXA classification of some fibres by computer analysis of the net peak areas, it may be possible to classify further fibres in the same sample on the basis of comparison of spectra at the instrument. Frequently, visual comparisons can be made after somewhat shorter acquisition times.

E.3 Interpretation of fibre analysis data

E.3.1 Chrysotile

The morphological structure of chrysotile is characteristic, and with experience, can be recognized readily. However, a few other minerals have similar appearance, and morphological observation by itself is inadequate for most samples. The ED pattern obtained from chrysotile is quite specific for this mineral if the specified characteristics of the pattern correspond to those from reference chrysotile. However, depending on the past history of the fibre, and on a number of other factors, the crystal structure of a particular fibre may be damaged, and it may not yield an ED pattern. In this case, the EDXA spectrum may be the only data available to supplement the morphological observations.

E.3.2 Amphiboles

Since the fibre identification procedure for asbestos fibres other than chrysotile can be involved and time-consuming, computer programmes such as that developed by Rhoades (see Bibliography) are recommended for interpretation of zone-axis ED patterns. The published literature contains composition and crystallographic data for all of the fibrous minerals likely to be encountered in TEM analysis of air samples, and the compositional and structural data from the unknown fibre should be compared with the published data. Demonstration that the measurements are consistent with the data for a particular test mineral does not uniquely identify the unknown, since the possibility exists that data from other minerals may also be consistent. It is, however, unlikely that a mineral of another structural class could yield data consistent with that from an amphibole fibre identified by quantitative EDXA and two zone-axis ED patterns.

Suspected amphibole fibres should be classified initially on the basis of chemical composition. Either qualitative or quantitative EDXA information may be used as the basis for this classification. From the published data on mineral compositions, a list of minerals which are consistent in composition with that measured for the unknown fibre should be compiled. To proceed further, it is necessary to obtain the first zone-axis ED pattern, according to the instructions in E.2.2.

It is possible to specify a particular zone-axis pattern for identification of amphibole, since a few patterns are often considered to be characteristic. Unfortunately, for a fibre with random orientation on a TEM grid, no specimen holder and goniometer currently available will permit convenient and rapid location of two preselected zone-axes. The most practical approach has been adopted, which is to accept those low index patterns which are easily obtained, and then to test their consistency with the structures of the minerals already preselected on the basis of the EDXA data. Test the structures of non-amphibole minerals in this preselected list against the zone-axis data obtained for the unknown fibre, since non-amphibole minerals in some orientations may yield similar patterns consistent with amphibole structures.

The zone-axis ED interpretation shall include all minerals previously selected from the mineral data file as being chemically compatible with the EDXA data. This procedure usually shortens the list of minerals for which solutions have been found. A second set of zone-axis data from another pattern obtained on the same fibre can then be processed, either as further confirmation of the identification, or to attempt elimination of an ambiguity. In addition, the angle measured between the orientations of the two zone-axes can be checked for consistency with the structures of the minerals. Caution should be exercised in rationalizing the inter-zone axis angle, since if the fibre contains *c*-axis twinning the two zone-axis ED patterns may originate from the separate twin crystals. In practice, the full identification procedure will normally be applied to very few fibres, unless for a particular reason precise identification of all fibres is required.

E.4 Fibre classification categories

It is not always possible to proceed to a definitive identification of a fibre; this may be due to instrumental limitations or to the actual nature of the fibre. In many analyses a definitive identification of each fibre may not actually be necessary if there is other knowledge available about the sample, or if the concentration is below a level of interest. The analytical procedure must therefore take account of both instrumental limitations and varied analytical requirements. Accordingly, a system for fibre classification is used to permit accurate recording of data. The classifications are shown in Tables E.1 and E.2, and are directed towards identification of chrysotile and amphibole respectively. Fibres shall be reported in these categories.

The general principle to be followed in this analytical procedure is first to define the most specific fibre classification which is to be attempted, or the "level" of analysis to be conducted. Then, for each fibre examined, record the classification which is actually achieved. Depending on the intended use of the results, criteria for acceptance of fibres as "identified" can then be established at any time after completion of the analysis.

In an unknown sample, chrysotile shall be regarded as confirmed only if a recorded, calibrated ED pattern from one fibre in the CD categories is obtained, or if measurements of the ED pattern are recorded at the instrument. Amphibole shall be regarded as confirmed only by obtaining recorded data which yields exclusively amphibole solutions for fibres classified in the AZQ, AZZ or AZZQ categories.

Table E.1 — Classification of fibres with tubular morphology

TM	-	<u>T</u> ubular <u>M</u> orphology, not sufficiently characteristic for classification as chrysotile
CM	-	Characteristic <u>C</u> hrysotile <u>M</u> orphology
CD	-	<u>C</u> hrysotile SAED pattern
CQ	-	<u>C</u> hrysotile composition by <u>Q</u> uantitative EDXA
CMQ	-	<u>C</u> hrysotile <u>M</u> orphology and composition by <u>Q</u> uantitative EDXA
CDQ	-	<u>C</u> hrysotile SAED pattern and composition by <u>Q</u> uantitative EDXA
NAM	-	<u>N</u> on- <u>A</u> sbestos <u>M</u> ineral

Table E.2 — Classification of fibres without tubular morphology

UF	-	<u>U</u> nidentified <u>F</u> ibre
AD	-	<u>A</u> mphibole by random-orientation SAED (shows layer pattern of 0,53 nm spacing)
AX	-	<u>A</u> mphibole by qualitative EDXA. Spectrum has elemental components consistent with amphibole
ADX	-	<u>A</u> mphibole by random-orientation SAED and qualitative EDXA
AQ	-	<u>A</u> mphibole by <u>Q</u> uantitative EDXA
AZ	-	<u>A</u> mphibole by one <u>Z</u> one Axis SAED pattern
ADQ	-	<u>A</u> mphibole by random orientation SAED and <u>Q</u> uantitative EDXA
AZQ	-	<u>A</u> mphibole by one <u>Z</u> one Axis SAED pattern and <u>Q</u> uantitative EDXA
AZZ	-	<u>A</u> mphibole by <u>two</u> <u>Z</u> one Axis SAED patterns with consistent interaxial angle
AZZQ	-	<u>A</u> mphibole by <u>two</u> <u>Z</u> one Axis SAED patterns, with consistent interaxial angle, and <u>Q</u> uantitative EDXA
NAM	-	<u>N</u> on- <u>A</u> sbestos <u>M</u> ineral

E.4.1 Procedure for classification of fibres with tubular morphology, suspected to be chrysotile

Occasionally, fibres are encountered which have tubular morphology similar to that of chrysotile, but which cannot be characterized further either by ED or EDXA. They can be non-crystalline, in which case ED techniques are not useful, or they can be in a position on the grid which does not permit an EDXA spectrum to be obtained. Alternatively, the fibre can be of organic origin, but the morphology and composition may not be sufficiently definitive that it can be disregarded. Accordingly, it is necessary to record each fibre, and to specify how confidently each fibre can be identified. Classification of fibres will meet with various degrees of success. Figure E.2 shows the classification procedure which shall be used for fibres which display any tubular morphology. The chart is self-explanatory, and every fibre is either rejected as a non-asbestos mineral (NAM), or classified in some way which by some later criterion could still contribute to the chrysotile fibre count.

Morphology is the first consideration, and if this is not similar to that usually seen in chrysotile standard samples, designate the initial classification as TM. Regardless of the doubtful morphology, examine the fibre by ED and EDXA methods according to Figure E.2. Where the morphology is more definitive, it may be possible to classify the fibre as having chrysotile morphology (CM).

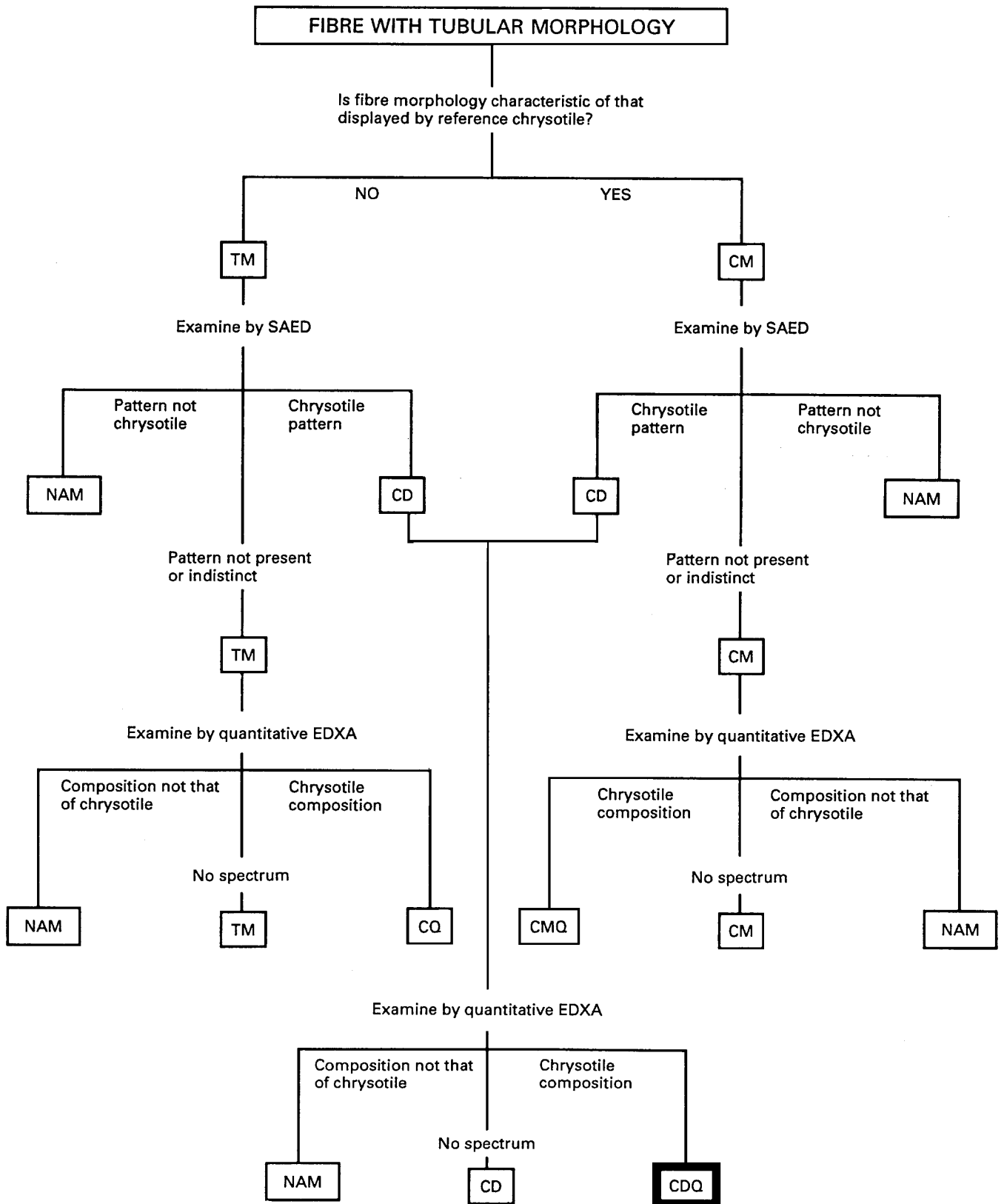

Figure E.2 — Classification chart for fibre with tubular morphology

For classification as CM, the morphological characteristics required are:

- a) the individual fibrils have high aspect ratios, exceeding 5:1, and are about 30 nm to 40 nm in diameter;
- b) the electron-scattering power of the fibre at 60 kV to 100 kV accelerating potential is sufficiently low for internal structure to be visible; and,
- c) there is some evidence of internal structure suggesting a tubular appearance similar to that shown by reference UICC chrysotile, which may degrade in the electron beam.

Examine every fibre having these morphological characteristics by the ED technique, and classify as chrysotile by ED (CD) only those which give diffraction patterns with the precise characteristics shown in Figure E.3. The relevant features in this pattern for identification of chrysotile are as follows:

- a) the (002) reflections shall be examined to determine that they correspond closely to a spacing of 0,73 nm;
- b) the layer line repeat distance corresponds to 0,53 nm; and,
- c) there is "streaking" of the (110) and (130) reflections.

Using the millimetre calibrations on the TEM viewing screen, these observations can readily be made at the instrument. If documentary proof of fibre identification is required, record a TEM micrograph of at least one representative fibre, and record its ED pattern on a separate film or plate. This film or plate shall also carry calibration rings from a known polycrystalline substance, such as gold. This calibrated pattern is the only documentary proof that the particular fibre is chrysotile, and not some other tubular or scrolled species such as halloysite, palygorskite, talc or vermiculite. The proportion of fibres which can be successfully identified as chrysotile by ED is variable, and to some extent dependent on both the instrument and the procedures of the operator. The fibres that fail to yield an identifiable ED pattern will remain in the TM or CM categories unless they are examined by EDXA.

In the EDXA analysis of chrysotile there are only two elements which are relevant. For fibre classification, the EDXA analysis shall be quantitative. If the spectrum displays prominent peaks from magnesium and silicon, with their areas in the appropriate ratio, and with only minor peaks from other elements, classify the fibre as chrysotile by quantitative EDXA, in the categories CQ, CMQ, or CDQ, as appropriate.

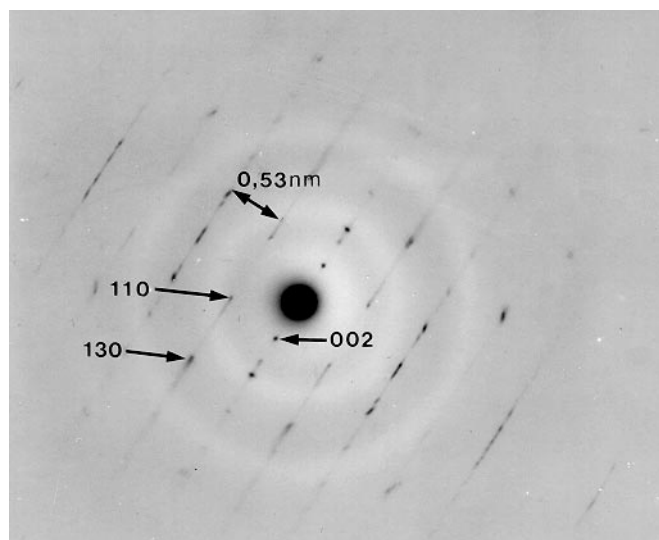

Figure E.3 — Chrysotile SAED pattern

E.4.2 Procedure for classification of fibres without tubular morphology, suspected to be amphibole

Every particle without tubular morphology and which is not obviously of biological origin, with an aspect ratio of 5:1 or greater, and having parallel or stepped sides, shall be considered as a suspected amphibole fibre. Further examination of the fibre by ED and EDXA techniques will meet with a variable degree of success, depending on the nature of the fibre and on a number of instrumental limitations. It is not possible to identify every fibre completely, even if time and cost are of no concern. Moreover, confirmation of the presence of amphibole can be achieved only by quantitative interpretation of zone-axis ED patterns, a very time-consuming procedure. Accordingly, for routine samples from unknown sources, this analytical procedure limits the requirement for zone-axis ED work to a minimum of one fibre representative of each compositional class reported. In some samples, it may be necessary to identify more fibres by the zone-axis technique. When analyzing samples from well-characterized sources, the cost of identification by zone-axis methods may not be justified.

The 0,53 nm layer spacing of the random-orientation ED pattern is not by itself diagnostic for amphibole. However, the presence of *c*-axis twinning in many fibres leads to contributions to the layers in the patterns by several individual parallel crystals of different axial orientations. This apparently random positioning of the spots along the layer lines, if also associated with a high fibre aspect ratio, is a characteristic of amphibole asbestos, and thus has some limited diagnostic value. If a pattern of this type is not obtained, the identity of the fibre is still ambiguous, since the absence of a recognizable pattern can be a consequence of an unsuitable orientation relative to the electron beam, or the fibre can be some other mineral species.

Figure E.4 shows the fibre classification chart which shall be used for suspected amphibole fibres. This chart shows all the classification paths possible in analysis of a suspected amphibole fibre, when examined systematically by ED and EDXA. Two routes are possible, depending on whether an attempt to obtain an EDXA spectrum or a random-orientation ED pattern is made first. The normal procedure for analysis of a sample of unknown origin is to examine the fibre by random-orientation ED, qualitative EDXA, quantitative EDXA, and zone-axis ED, in this sequence. The final fibre classification assigned is defined either by successful analysis at the maximum required level, or by the instrumental limitations. Any instrumental limitations which affect the quality of the results shall be noted. Record the maximum classification achieved for each fibre on the counting sheet in the appropriate column. The various classification categories can then be combined later in any desired way for calculation of the fibre concentration. The complete record of the results obtained when attempting to identify each fibre can also be used to re-assess the data if necessary.

In the unknown sample, zone-axis analysis will be required if the presence of amphibole is to be unequivocally confirmed. For this level of analysis, attempt to raise the classification of every suspected amphibole fibre to the ADQ category by inspection of the random orientation ED pattern and the EDXA spectrum. In addition, examine at least one fibre from each type of suspected amphibole found by zone-axis methods to confirm their identification. In most cases, because information exists about possible sources of asbestos in close proximity to the air sampling location, some degree of ambiguity of identification can be accepted. Lower levels of analysis can therefore be accepted for these situations.

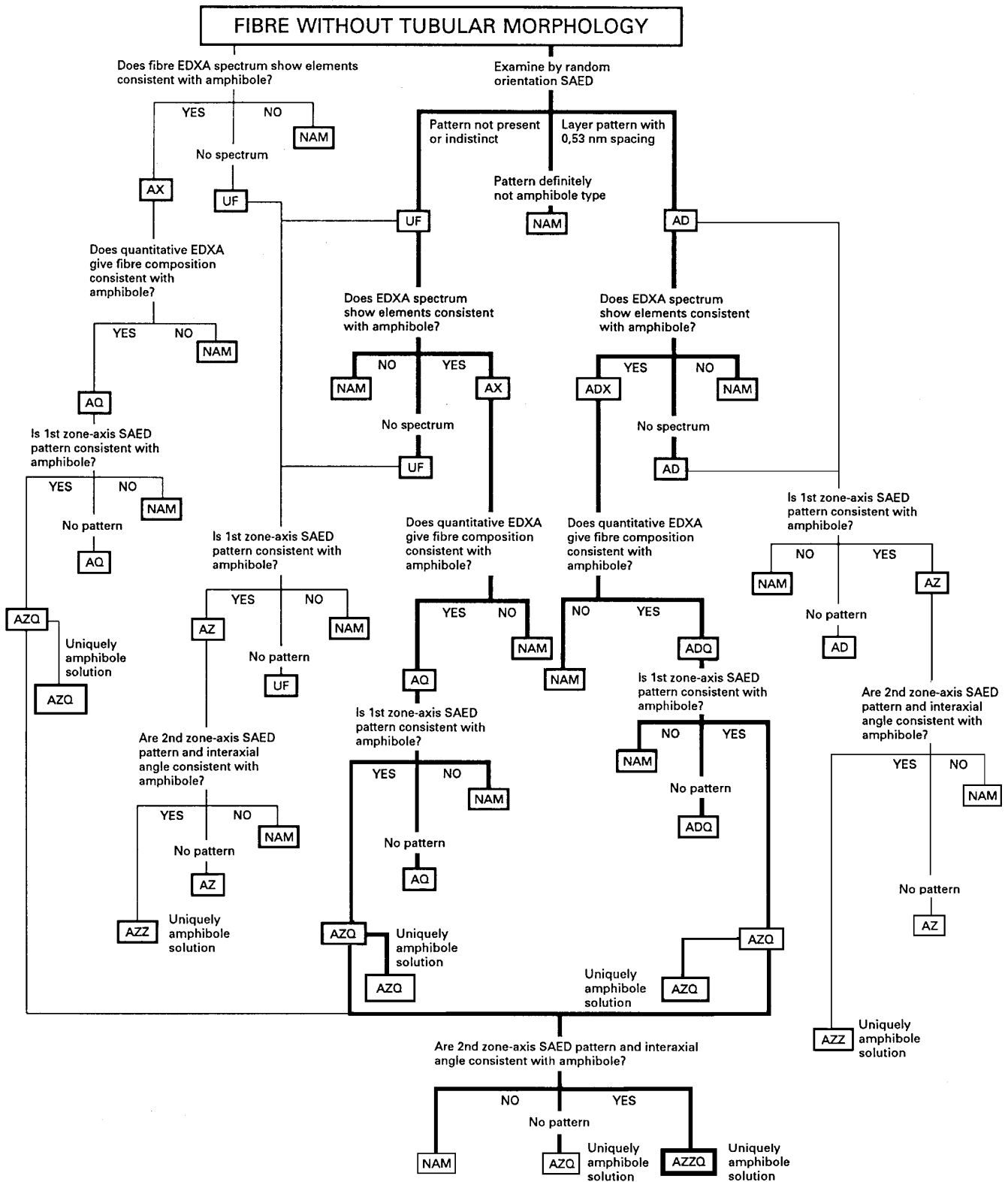

Figure E.4 — Classification chart for fibre without tubular morphology

Annex F (normative)

Determination of concentrations of asbestos fibres and bundles longer than 5 µm, and of PCM-equivalent asbestos fibres

In order to provide increased statistical precision and improved analytical sensitivity for those asbestos fibres and bundles longer than 5 µm, it may be decided to perform additional fibre counting at a lower magnification, taking account only of fibres and bundles within this dimensional range. The result shall be specified as "asbestos fibres and bundles longer than 5 µm". For this examination, use a magnification of approximately 10 000×, and continue to assign a morphological code to each structure according to the procedures in annex D. Record fibres and bundles only if their lengths exceed 5 µm. Record cluster and matrix components only if their lengths exceed 5 µm.

It may also be decided to provide increased statistical precision and improved analytical sensitivity for fibrous structures longer than 5 µm that have diameters between 0,2 µm and 3,0 µm, which have historically been the basis of risk estimation in the occupational environment (PCM-equivalent asbestos fibres). Use a magnification of approximately 5 000× for this extended fibre count. The result shall be specified as "PCM-equivalent asbestos fibres". Asbestos structures within this dimensional range do not necessarily incorporate asbestos fibres or bundles longer than 5 µm.

Continue the extended sample examination until 100 asbestos structures have been counted, or until a sufficient area of the specimen has been examined to achieve the desired analytical sensitivity calculated according to Table 1. The grid openings examined shall be divided approximately equally between a minimum of two specimen grids.

NOTE The specimen area corresponding to the area of filter examined in the PCM fibre-counting methods is 0,785 mm², and is equivalent to approximately 100 grid openings of a 200 mesh grid.

Some national standards require that asbestos fibres longer than 2,5 µm, with diameters between 0,2 µm and 3,0 µm be counted. Use a magnification of 5 000× for counting fibres within these dimensional ranges.

The minimum aspect ratio for definition of a fibre in PCM fibre-counting methods and in some national standards is 3:1. Use of a 3:1 aspect ratio is permitted in this International Standard, if this aspect ratio is specified in the test report.

The test reports shall include all of the items specified in clause 10.

Annex G (normative)

Calculation of results

G.1 Introduction

Calculate the results using the procedures described below. The results can be conveniently calculated using a computer program.

G.2 Test for uniformity of distribution of fibrous structures on TEM grids

A check shall be made using the chi-squared test, to determine whether the asbestos structures found on individual grid openings are randomly and uniformly distributed among the grid openings. If the total number found in k grid openings is n , and the areas of the k individual grid openings are designated A_1 to A_k , then the total area of TEM specimen examined is:

$$A = \sum_{i=1}^{i=k} A_i$$

The fraction of the total area examined which is represented by the individual grid opening area, p_i , is given by A_i/A . If the structures are randomly and uniformly dispersed over the k grid openings examined, the expected number of structures falling in one grid opening with area A_i is $n \cdot p_i$. If the observed number of structures found on that grid opening is n_i , then:

$$\chi^2 = \sum_{i=1}^{i=k} \frac{n_i - n \cdot p_i}{n \cdot p_i}$$

This value shall be compared with significance points of the χ^2 distribution, having $(k - 1)$ degrees of freedom. Significance levels lower than 0,1 % may be cause for the sample analysis to be rejected, since this corresponds to a very heterogeneous deposit. If the structure count fails this test, the precision of the result will be uncertain. The precision of the result may be improved by examination of additional grid openings. Inhomogeneous deposits of particulate occur either as a result of incomplete dispersal of the residues after ashing, or during filtration of the aqueous dispersions. Accordingly, the optimum approach is to prepare new TEM specimens from the original sample collection filter.

G.3 Calculation of the analytical sensitivity

Calculate the analytical sensitivity S , in structures/litre, using the formula:

$$S = \frac{(A_a \cdot V_d)}{(k \cdot A_g \cdot V_f \cdot F_a \cdot V_s)}$$

where

S is the required analytical sensitivity, expressed in structures/litre;

A_a is the active area, expressed in square millimetres (mm²), of analytical filter;

V_d is the volume of water, expressed in millilitres (ml), used for dispersal of residual ash;

k is the number of grid openings examined;

A_g is the area, expressed in square millimetres (mm²), of TEM specimen grid opening;

V_f is the volume, expressed in millilitres (ml), of aqueous dispersion filtered;

F_a is the fraction of sample collection filter ashed;

V_s is the volume, expressed in litres (l), of air sampled.

G.4 Calculation of the mean and confidence interval of the structure concentration

G.4.1 General

In the structure count made according to this International Standard, a number of grid openings have been sampled from a population of grid openings, and the mean grid opening structure count for the population shall be determined on the basis of this small sample. The interval about the sample mean, which, with 95 % confidence, contains the population mean, is also required.

G.4.2 Calculation of the mean structure concentration

Calculate the mean structure concentration, C , in structures/litre:

$$C = S \cdot n$$

where

S is the analytical sensitivity, expressed in structures/litre;

n is the total number of structures found on all grid openings examined.

G.4.3 Calculation of confidence intervals

The distribution of structures on the grid openings should theoretically approximate to a Poisson distribution. Because of fibre aggregation and size-dependent identification effects, the actual structure counting data often does not conform to the Poisson distribution, particularly at high structure counts. An assumption that the structure-counting data are distributed according to the Poisson distribution can therefore lead to confidence intervals narrower than are justified by the data. Moreover, if the Poisson distribution is assumed, the variance is related only to the total number of structures counted. Thus a particular structure count conducted on one grid opening is considered to have the same confidence interval as that for the same number of structures found on many grid openings. However, the area of sample actually counted is very small in relation to the total area of the filter, and for this reason structures shall be counted on a minimum of four grid openings taken from different areas of the filter in order to ensure that a representative evaluation of the deposit is made.

At high structure counts, where there are adequate numbers of structures per grid opening to allow a sample estimate of the variance to be made, the distribution can be approximated to a Gaussian, with independent values for the mean and variance. Where the sample estimate of variance exceeds that implicit in the Poissonian assumption, use of Gaussian statistics with the variance defined by the actual data is the most conservative approach to calculation of confidence intervals.

At low structure counts, it is not possible to obtain a reliable sample estimate of the variance, and the distribution also becomes asymmetric but not necessarily Poissonian. For 30 structures and below, the distribution becomes sufficiently asymmetric that the fit to a Gaussian is no longer a reasonable one, and estimates of sample variance are unreliable. Accordingly, for counts below 31 structures, the assumption of a Poisson distribution shall be made for calculation of the confidence intervals.

G.4.4 Example of calculation of Poissonian confidence intervals

For total structure counts less than four, the lower 95 % confidence limit corresponds to less than one structure. Therefore, it is not meaningful to quote lower confidence interval points for structure counts of less than four, and the result shall be specified as "less than" the corresponding one-sided upper 95 % confidence limit of the Poisson distribution. These are as follows:

0 structures: 2,99 times the analytical sensitivity

one structure: 4,74 times the analytical sensitivity

two structures: 6,30 times the analytical sensitivity

three structures: 7,75 times the analytical sensitivity

For total counts exceeding four, the 95 % confidence interval shall be calculated using the values shown in Table G.1. Table G.1 gives the upper and lower limits of the two-sided Poissonian 95 % confidence interval for structure counts up to 470.

G.4.5 Example of calculation of Gaussian 95 % confidence intervals

Calculate the sample estimate of variance s^2 as follows:

$$s^2 = \sum_{i=1}^{i=k} \frac{(n_i - n \cdot p_i)^2}{(k-1)}$$

where

n_i is the number of structures on the i 'th grid opening;

n is the total number of structures found in k grid openings;

P_i is the fraction of the total area examined represented by the i 'th grid opening;

k is the number of grid openings.

If the mean value of the structure count is calculated to be n , the upper and lower values of the Gaussian 95 % confidence interval are given by:

where

$$n_L = \frac{n}{k} - \frac{t \cdot s}{\sqrt{k}}$$

$$n_U = \frac{n}{k} + \frac{t \cdot s}{\sqrt{k}}$$

n_U is the upper 95 % confidence limit;

n_L is the lower 95 % confidence limit;

n is the total number of structures in all grid openings examined;

t is the value of Student's "t" (probability 0,975) for $(k-1)$ degrees of freedom;

s is the standard deviation (square root of sample estimate of variance);

k is the number of grid openings.

G.4.6 Summary of procedure for calculation of results

In summary, structure-counting data shall be calculated as follows:

- a) no structures detected: The structure concentration shall be reported as less than the concentration equivalent to the one-sided upper 95 % confidence limit of the Poisson distribution. This is equal to 2,99 times the analytical sensitivity.
- b) from one to three structures: When one to three structures are counted, the result shall be reported as less than the corresponding one-sided upper 95 % confidence limit for the Poisson distribution. These are as follows:
 - 1) one structure: 4,74 times the analytical sensitivity;
 - 2) two structures: 6,30 times the analytical sensitivity;
 - 3) three structures: 7,75 times the analytical sensitivity.
- c) from four to 30 structures: The mean structure concentration and the 95 % confidence intervals shall be reported on the basis of the Poisson assumption, using the values shown in Table G1.
- d) more than 30 structures: When more than 30 structures are counted, both the Gaussian 95 % confidence interval and the Poisson 95 % confidence interval shall be calculated. The larger of these two intervals shall be used to express the precision of the structure concentration. When the Gaussian 95 % confidence interval is selected for data reporting, the Poisson 95 % confidence interval shall also be specified.

G.5 Calculation of structure length, width, and aspect ratio distributions

G.5.1 General

The distributions all approximate to logarithmic-normal, and so the size-range intervals for calculation of the distribution shall be spaced logarithmically. The other characteristics required for the choice of size intervals are that they should allow for a sufficient number of size classes, while still retaining a statistically valid number of structures in each class. Interpretation is also facilitated if each size class repeats at decade intervals, and if 5 µm is a size class boundary. A ratio from one class to the next of 1,468 satisfies all of these requirements and this value shall be used. The distributions, being approximately logarithmic-normal, when presented graphically, shall be plotted using a logarithmic-scale ordinate and a Gaussian abscissa.

G.5.2 Calculation of structure length cumulative number distribution

This distribution allows the fraction of the total number of structures either shorter or longer than a given length to be determined. It is calculated using the relationship:

$$C(P)_k = \frac{\sum_{i=1}^{i=k} n_i}{\sum_{i=1}^{i=P} n_i} \times 100$$

where

$C(P)_k$ is the cumulative number percentage of structures which have lengths less than the upper bound of the k 'th class;

n_i is the number of structures in the i 'th length class;

P is the total number of length classes.

G.5.3 Calculation of structure-width cumulative number distribution

This distribution allows the fraction of the total number of structures either narrower or wider than a given width to be determined. It is calculated in a manner similar to that used in G.5.2, but using the structure widths.

G.5.4 Calculation of structure aspect-ratio cumulative number distribution

This distribution allows the fraction of the total number of structures which have aspect ratios either smaller or larger than a given aspect ratio to be determined. It is calculated in a manner similar to that used in G.5.2, but using the structure aspect ratios.

G.6 Calculation of an estimate of mass concentration of asbestos fibres and bundles

An estimate of the mass concentration of asbestos fibres and bundles can be calculated from the results of a TEM examination conducted according to the procedure specified in D.6. It is calculated using the relationship:

$$M = 0,25 \cdot \pi \cdot S \cdot D \cdot 10^{-3} \cdot \sum_{j=1}^{j=n} w_j^2 \cdot L_j$$

where

M is the estimate of mass concentration of asbestos, expressed in nanograms per cubic metre (ng/m³);

S is the analytical sensitivity, expressed in structures/litre;

w_j is the width of the j 'th structure, expressed in micrometres (μm);

L_j is the length of the j 'th structure, expressed in micrometres (μm);

D is the density of the variety of asbestos, expressed in kilograms per cubic metre (kg/m³);

n is the total number of asbestos fibres and bundles recorded in k grid openings

In the above relationship, assume the densities of the asbestos varieties to be as follows: chrysotile 2 550 kg/m³, crocidolite 3 370 kg/m³, amosite 3 430 kg/m³, anthophyllite 3 000 kg/m³, tremolite 3 000 kg/m³, actinolite 3 100 kg/m³. Densities of the asbestos varieties vary with composition, but the values specified are sufficiently accurate for the purposes of this calculation.

NOTE The above calculation does not include contributions from compact clusters, compact matrices, cluster residuals or matrix residuals, because the total volume of the constituent asbestos fibres in these structures cannot be estimated reliably.

Table G.1 — Upper and lower limits of the Poissonian 95 % confidence interval of a count

Structure count	Lower	Upper	Structure count	Lower	Upper	Structure count	Lower	Upper
0	0	* 3,689	46	33,678	61,358	92	74,164	112,83
1	0,025	5,572	47	34,534	62,501	93	75,061	113,94
2	0,242	7,225	48	35,392	63,642	94	75,959	115,04
3	0,619	8,767	49	36,251	64,781	95	76,858	116,14
4	1,090	10,242	50	37,112	65,919	96	77,757	117,24
5	1,624	11,669	51	37,973	67,056	97	78,657	118,34
6	2,202	13,060	52	38,837	68,192	98	79,557	119,44
7	2,814	14,423	53	39,701	69,326	99	80,458	120,53
8	3,454	15,764	54	40,567	70,459	100	81,360	121,66
9	4,115	17,085	55	41,433	71,591	110	90,400	132,61
10	4,795	18,391	56	42,301	72,721	120	99,490	143,52
11	5,491	19,683	57	43,171	73,851	130	108,61	154,39
12	6,201	20,962	58	44,041	74,979	140	117,77	165,23
13	6,922	22,231	59	44,912	76,106	150	126,96	176,04
14	7,654	23,490	60	45,785	77,232	160	136,17	186,83
15	8,396	24,741	61	46,658	78,357	170	145,41	197,59
16	9,146	25,983	62	47,533	79,482	180	154,66	208,33
17	9,904	27,219	63	48,409	80,605	190	163,94	219,05
18	10,668	28,448	64	49,286	81,727	200	173,24	229,75
19	11,440	29,671	65	50,164	82,848	210	182,56	240,43
20	12,217	30,889	66	51,042	83,969	220	191,89	251,10
21	13,000	32,101	67	51,922	85,088	230	201,24	261,75
22	13,788	33,309	68	52,803	86,207	240	210,60	272,39
23	14,581	34,512	69	53,685	87,324	250	219,97	283,01
24	15,378	35,711	70	54,567	88,441	260	229,36	293,62
25	16,178	36,905	71	55,451	89,557	270	238,75	304,23
26	16,983	38,097	72	56,335	90,673	280	248,16	314,82
27	17,793	39,284	73	57,220	91,787	290	257,58	325,39
28	18,606	40,468	74	58,106	92,901	300	267,01	335,96
29	19,422	41,649	75	58,993	94,014	310	276,45	346,52
30	20,241	42,827	76	59,880	95,126	320	285,90	357,08
31	21,063	44,002	77	60,768	96,237	330	295,36	367,62
32	21,888	45,175	78	61,657	97,348	340	304,82	378,15
33	22,715	46,345	79	62,547	98,458	350	314,29	388,68
34	23,545	47,512	80	63,437	99,567	360	323,77	399,20
35	24,378	48,677	81	64,328	100,68	370	333,26	409,71
36	25,213	49,840	82	65,219	101,79	380	342,75	420,22
37	26,050	51,000	83	66,111	102,90	390	352,25	430,72
38	26,890	52,158	84	67,003	104,00	400	361,76	441,21
39	27,732	53,315	85	67,897	105,11	410	371,27	451,69
40	28,575	54,469	86	68,790	106,21	420	380,79	462,18
41	29,421	55,622	87	69,684	107,32	430	390,32	472,65
42	30,269	56,772	88	70,579	108,42	440	399,85	483,12
43	31,119	57,921	89	71,474	109,53	450	409,38	493,58
44	31,970	59,068	90	72,370	110,63	460	418,92	504,04
45	32,823	60,214	91	73,267	111,73	470	428,47	514,50

*The one-sided upper 95 % confidence limit for zero structures is 2,99.

Annex H (normative)

Test procedure to determine suitability of cellulose ester sample collection filters

H.1 Introduction

The residue remaining after ashing of unused cellulose ester filters primarily consists of aggregates of small particles of silica. This residue does not interfere with the analysis, other than imposing a limit on the degree of concentration that can be achieved. The residue from some varieties of cellulose ester filter, in addition to these small particles, also contains fragments of a silica film which originates from the surface of the original filter. The majority of the particles originally on the surface of the filter are bonded together by this silica film, which shrinks to a small area during the plasma ashing procedure. This fragment of silica film usually does not disperse completely in water. The resulting TEM specimens exhibit a much reduced particulate deposition on most of the grid openings, which will lead to a serious negative bias in the result. A few large fragments of silica film to which most of the particles are attached may be observed on a few of the grid openings. Membrane filters which exhibit this type of behaviour are unsuitable for use with this analytical method. Before air samples are collected, filters from the actual lot number to be used shall be tested in order to ensure that they do not exhibit this defect.

H.2 Test procedure

The optimum method for testing the suitability of the cellulose ester filters is to compare specimen grids prepared by the indirect-transfer procedure with grids prepared from the same filter using the direct-transfer procedure. The filter used for this test shall have a uniform deposit of single asbestos fibres, collected by air deposition, on its surface. The performance of a filter is satisfactory if it yields a numerical recovery close to 100 % for the indirect-transfer preparation, and also if no evidence of the effect described in H.1 is observed on the grids prepared by the indirect-transfer procedure.

Alternatively, blank filters can be tested by the following procedure. Evaporate a film 5 nm to 10 nm thick of carbon onto approximately 5 cm² of the uncollapsed cellulose ester filter to be tested. Prepare a Jaffe washer using a 3 cm × 3 cm piece of type 304 stainless steel woven cloth with approximately 80 mesh repeats per centimetre. Add dimethylformamide to the washer until the meniscus just contacts the underside of the mesh. Place the carbon-coated filter portion on the mesh, with the carbon side facing upwards. After a period of approximately 2 h, using a pipette, remove the dimethylformamide and re-fill the Jaffe washer with new dimethylformamide. After a further period of 2 h, remove the mesh supporting the carbon replica from the Jaffe washer and place it into a clean 50 ml borosilicate glass beaker. Allow the solvent on the mesh to evaporate. After the mesh is dry, cover the beaker with aluminium foil and perforate the foil as specified in clause 10. Ash the carbon replica in the same way as specified for ashing of filters in clause 10. The particulate residues from the carbon replica remain loosely attached to the stainless steel mesh after this operation. Leaving the stainless steel mesh in the beaker throughout, prepare TEM specimen grids by the procedure specified in clause 10 for analysis of blank filters. Examine the TEM specimens for the presence of tabular particles, from which the EDXA spectrum exhibits only a Si K α peak. If the concentration of such tabular particles is more than 100 particles/mm², the filters are unsatisfactory for use with this analytical method.

Annex I

(informative)

Strategies for collection of air samples

I.1 Introduction

An important part of the sampling strategy is a statement of the purpose of the sampling programme. A sufficient number of samples should be collected so that the site is well characterized to the precision and accuracy desired, and also ensure that sample filters appropriately-loaded for TEM analysis are obtained from all of the sampling locations.

I.2 Air sample collection in the outdoors environment

Weather conditions restrict the ability to collect satisfactory air samples in the outdoors environment, and whenever possible, sampling should be carried out in low-wind, low-humidity conditions. Detailed records of the weather conditions, wind speed and direction during the sampling period should be made. All available information concerning local topography, and the types and positions of sources, should be recorded.

Sequential multipoint sampling is necessary to provide adequate characterization of complex sites and sources. It is recommended that multiple samples be taken upwind and downwind of the site, with a minimum of two samples in the downwind position expected to experience the maximum airborne concentration. The locations of the samplers should be carefully recorded.

I.3 Air sample collection inside buildings

Air samples are often collected inside buildings in which asbestos-containing construction materials are present, in order to determine whether these materials contribute to the asbestos concentration in the building atmosphere. The optimum positions for collection of air samples can be determined only after a complete survey of the building to establish air movement patterns. Multiple samples should be collected in the area where asbestos building materials are present, and control samples should be collected in an adjacent area where no airborne asbestos fibres would be expected. The intakes for air-conditioning systems are frequently used as the control sample collection locations. Whenever possible, static samples should be taken over a period exceeding 4 h during normal activity in the building, at face velocities of between 4 cm/s and 70 cm/s.

Bibliography

- [1] ISO 4225, *Air quality — General aspects — Vocabulary*.
- [2] ISO 4226, *Air quality — General aspects — Units of measurement*.
- [3] ISO 5725-2, *Accuracy (trueness and precision) of measurement methods and results — Part 2: Basic method for the determination of repeatability and reproducibility of a standard measurement method*.
- [4] ISO 7708, *Air quality — Particle size fraction definitions for health-related sampling*.
- [5] ISO 10312, *Ambient air — Determination of asbestos fibres — Direct-transfer transmission electron microscopy method*.
- [6] Asbestos International Association (1979): *Reference method for the determination of asbestos fibre concentrations at workplaces by light microscopy (membrane filter method)*. AIA health and safety publication, recommended technical method No. 1 (RTM1). Asbestos International Association, 68 Gloucester Place, London, W1H 3HL, UK.
- [7] BRADLEY, D.E. (1961): Replica and shadowing techniques. In: *Techniques for Electron Microscopy*, D.H. KAY (Ed.) Blackwell Scientific Publications, Alden, Oxford, UK, pp. 96-152.
- [8] BURDETT, G.J. and ROOD, A.P. (1982): Membrane-filter, direct transfer technique for the analysis of asbestos fibres or other inorganic particles by transmission electron microscopy. *Environ. Sci. Technol.*, **17**, pp. 643-648.
- [9] CAMPBELL, W.J., BLAKE, R.L., BROWN, L.L., CATHER, E.E. and SJOBERG, J.J. (1977): *Selected silicate minerals and their asbestiform varieties. Mineralogical definitions and identification-characterization*. Information circular 8751. United States Department of the Interior, Bureau of Mines, Washington, D.C.
- [10] CHATFIELD, E.J. (1986): Asbestos measurements in workplaces and ambient atmospheres. In: *Electron microscopy in forensic, occupational, and environmental health sciences*, S. BASU and J.R. MILLETTE, (Eds.), Plenum Press, New York, pp. 149-186.
- [11] CHATFIELD, E.J. (Ed.) (1987): *Asbestos fibre measurements in building atmospheres*. Ontario Research Foundation, Sheridan Park Research Community, Mississauga, Ontario, Canada, L5K 1B3.
- [12] CHATFIELD, E.J. and LEWIS, G.M. (1980): Development and application of an analytical technique for measurement of asbestos fibers in vermiculite. In: *Scanning Electron Microscopy/1980/I*, O. JOHARI (Ed.), SEM Inc., AMF O'HARE, Chicago, IL 60666, U.S.A.
- [13] CLIFF, G. and LORIMER, G.W. (1975): The quantitative analysis of thin specimens. *J. Microscop.*, **103**, pp. 203-207.
- [14] DEER, W.A., HOWIE, R.A. and ZUSSMAN, J. (1963): *Rock-forming minerals*. Longmans, London, UK.
- [15] Federal Register (1987): *Asbestos-containing materials in schools*. U.S. Environmental Protection Agency. Vol. 42, No. 210, October 30, 1987, pp. 41826-41905.
- [16] GARD, J.A. (Ed.) (1971): *The Electron Optical Investigation of Clays*. Mineralogical Society, 41 Queen's Gate, London S.W.7, UK.
- [17] GAZE, R. (1965): The physical and molecular structure of asbestos. *Anna N.Y. Acad. Sci.*, **132**, pp. 23-30.
- [18] HAWTHORNE, F.C. (1983): The crystal chemistry of the amphiboles. *Can. Mineral.*, **21**, Part 2, pp. 173-480.
- [19] HIRSCH, P.B., HOWIE, A., NICHOLSON, R.B., PASHLEY, D.W. and WHELAN, M.J. (1965): *Electron microscopy of thin crystals*. Butterworths, London, UK, pp. 18-23.

- [20] HOLLAHAN, J.R. and BELL, A.T. (Eds.) (1974): *Techniques and applications of plasma chemistry*. Wiley, New York, USA.
- [21] International Centre for Diffraction Data (1987): *Powder diffraction file*. International Centre for Diffraction Data, 1606 Park Lane, Swarthmore, PA 19081, U.S.A.
- [22] International Mineralogical Association (1978): Nomenclature of amphiboles (compiled by B.E. Leake), *Can. Mineral.*, **16**, p. 501.
- [23] ISO 8672:1982, *Determination of airborne inorganic fibre concentrations in workplaces by light microscopy (membrane filter method)*.
- [24] JAFFE, M.S. (1948): Handling and washing fragile replicas. *J. Appl. Phys.*, **19**, p. 1187.
- [25] JOY, D.C., ROMIG Jr., A.D. and GOLDSTEIN, J.I. (Eds.) (1986): *Principles of analytical electron microscopy*. Plenum Press, New York and London.
- [26] LEDOUX, R.L. (Ed.) (1979): Short course in mineralogical techniques of asbestos determination. Mineralogical Association of Canada, Department of Mineralogy, Royal Ontario Museum, 100 Queen's Park, Toronto, Ontario, Canada, M5S 2C6.
- [27] LEVADIE, B. (Ed.) (1984): Definitions for asbestos and other health-related silicates. ASTM Special Technical Publication 834. American Society for Testing and Materials, 1916 Race Street, Philadelphia, PA 19103, U.S.A.
- [28] MICHAEL, J.R. and WILLIAMS, D.B. (1987): A consistent definition of probe size and spatial resolution in the analytical electron microscope. *J. Microscop.*, **147**, pp. 289-303.
- [29] MICHAELS, L. and CHISSICK, S.S. (Eds.) (1979): *Asbestos (Vol. 1), Properties, applications and hazards*, Wiley, New York.
- [30] National Bureau of Standards Special Publication 506 (1978): *Workshop on asbestos: definitions and measurement methods*. U.S. Government Printing Office, Washington, D.C. 20402.
- [31] National Bureau of Standards Special Publication 619 (1982): *Asbestos standards: materials and analytical methods*. U.S. Government Printing Office, Washington, D.C. 20402.
- [32] National Institute for Occupational Safety and Health (1989): *NIOSH Method 7400*, Revision #3, 5/15/89. U.S. Department of Health and Human Services, Public Health Service, Centers for Disease Control, National Institute for Occupational Safety and Health, 4676 Columbia Parkway, Cincinnati, OH 45226, U.S.A.
- [33] National Institute for Occupational Safety and Health (1989): *NIOSH Method 7402*, Revision #1, 5/15/89. U.S. Department of Health and Human Services, Public Health Service, Centers for Disease Control, National Institute for Occupational Safety and Health, 4676 Columbia Parkway, Cincinnati, OH 45226, U.S.A.
- [34] NATRELLA, M.G. (1966): *Experimental statistics*: National Bureau of Standards Handbook 91. U.S. Government Printing Office, Washington D.C. 20402.
- [35] ORTIZ, L.W. and ISOM, B.L. (1974): Transfer technique for electron microscopy of membrane filter samples. *Amer. Ind. Hygiene Assoc. J.*, **35**(7), pp. 423-425.
- [36] PEARSON, E.S. and HARTLEY, H.O. (1958): *Biometrika tables for statisticians*, Vol. 1. Cambridge University Press, 32 East 57th Street, New York 22, NY, U.S.A.
- [37] RHOADES, B.L. (1976): *XIDENT- A computer technique for the direct indexing of electron diffraction spot patterns*. Research Report 70/76. Dept. of Mechanical Engineering, Univ. of Canterbury, Christchurch, New Zealand.
- [38] RING, S.J. (1980): Identification of amphibole fibers, including asbestos, using common electron diffraction patterns. In: *Electron Microscopy and X-ray Applications to Environmental and Occupational Health Analysis*, P.A. RUSSELL (Ed.), Vol. II, Ann Arbor Press, Ann Arbor, MI 48106, U.S.A.

- [39] RUSSELL, P.A. and HUTCHINGS, A.E. (1978): *Electron microscopy and X-ray applications to environmental and occupational health analysis*. Ann Arbor Science Publishers Inc., P.O. Box 1425, Ann Arbor, MI 48106, U.S.A.
- [40] SMALL, J.A., HEINRICH, K.F.J., NEWBURY, D.E. and MYKLEBUST, R.L. (1979): Progress in the development of the peak-to-background method for the quantitative analysis of single particles with the electron probe. *Scanning Electron Microscopy/1979/II*, O. JOHARI (Ed.). SEM Inc., AMF O'HARE, Chicago, IL 60666, U.S.A.
- [41] SMALL, J.A., STEEL, E.B. and SHERIDAN, P.J. (1985): Analytical standards for the analysis of chrysotile asbestos in ambient environments. *Anal. Chem.*, **57**, pp. 204-208.
- [42] SMITH, J.E. and JORDAN, M.L. (1964): Mathematical and graphical interpretation of the log-normal law for particle size distribution analysis. *J. Colloid Sci.*, **19**, pp. 549-559.
- [43] SPURNY, K.R., STOBER, H., OPELIA, H. and WEISS, G. (1979): On the evaluation of fibrous particles in remote ambient air. *Sci. Total Environ.*, **II**, pp. 1-40.
- [44] SPURNY, K.R. (Ed.) (1986): *Physical and chemical characterization of individual airborne particles*. Wiley, New York, USA.
- [45] STEEL, E.B. and SMALL, J.A. (1985): Accuracy of transmission electron microscopy for the analysis of asbestos in ambient environments. *Anal. Chem.*, **57**, pp. 209-213.
- [46] STEEL, E.B. and WYLIE, A. (1981): Mineralogical characteristics of asbestos. In: *Geology of Asbestos Deposits*, P.H. RIORDEN (Ed.), SME-AIME, pp. 93-101.
- [47] WENK, H.R. (Ed.) (1976): *Electron microscopy in mineralogy*. Springer-Verlag, New York, USA.
- [48] YADA, K. (1967): Study of chrysotile asbestos by a high resolution electron microscope. *Acta Crystallog.*, **23**, pp. 704-707.
- [49] ZUSSMAN, J. (1979): The mineralogy of asbestos. In: *Asbestos: Properties, Applications and Hazards*, Wiley, New York, USA, pp. 45-67.

